

FREIGHTLINER SPECIFICATION PROPOSAL

Vehicle Configuration

M2 106 CONVENTIONAL CHASSIS
2022 MODEL YEAR SPECIFIED
SET BACK AXLE - TRUCK

General Service

FIRE/EMERGENCY SERVICE
MEDIUM TRUCK 2 YEAR WARRANTY
EXPECTED FRONT AXLE LOAD: 12000 lbs
EXPECTED REAR DRIVE AXLE LOAD: 27000 lbs
EXPECTED GROSS VEHICLE CAPACITY: 39000 lbs

Engine

CUM L9 360EV HP @ 2200 RPM, 2200 GOV RPM, 1150 LB/FT
@ 1200 RPM, FIRE/EMERGENCY

Engine Equipment

2016 ONBOARD DIAGNOSTICS/2010 EPA/CARB/GHG21
NFPA COMPLIANT EMBER SCREEN AND FIRE RETARDANT
DONALDSON AIR CLEANER
DR 12V 275 AMP 40-SI BRUSHLESS PAD ALTERNATOR
WITH REMOTE BATTERY VOLTAGE SENSE
(3) DTNA GENUINE, FLOODED STARTING, MIN 2250CCA,
510RC, THREADED STUD BATTERIES WITH POSITIVE JUMP
START POST
BATTERY BOX FRAME MOUNTED
WIRE GROUND RETURN FOR BATTERY CABLES WITH
ADDITIONAL FRAME GROUND RETURN
POSITIVE LOAD DISCONNECT WITH CAB MOUNTED
CONTROL SWITCH MOUNTED OUTBOARD DRIVER SEAT
CUMMINS TURBOCHARGED 18.7 CFM AIR COMPRESSOR
WITH INTERNAL SAFETY VALVE
CUMMINS ENGINE INTEGRAL BRAKE WITH VARIABLE
GEOMETRY TURBO ON/OFF WITH BRAKE LAMPS
RH MTD HORIZONTAL AFTERTREATMENT SYSTEM
ASSEMBLY WITH RH HORIZONTAL TAILPIPE
HORTON DRIVEMASTER ADVANTAGE ON/OFF FAN DRIVE
AUTOMATIC FAN CONTROL WITHOUT DASH SWITCH, NON
ENGINE MOUNTED
CUMMINS SPIN ON FUEL FILTER
COMBINATION FULL FLOW/BYPASS OIL FILTER

1100 SQUARE INCH ALUMINUM RADIATOR WITH AUXILIARY COOLING
ANTIFREEZE TO -34F, OAT (NITRITE AND SILICATE FREE) EXTENDED LIFE COOLANT
GATES BLUE STRIPE COOLANT HOSES OR EQUIVALENT CONSTANT TENSION HOSE CLAMPS FOR COOLANT HOSES
ELECTRIC GRID AIR INTAKE WARMER
DELCO 12V 38MT HD STARTER WITH INTEGRATED MAGNETIC SWITCH

Transmission

ALLISON 3000 EVS 5 SPD AUTOMATIC TRANSMISSION

Transmission Equipment

MAGNETIC PLUGS, ENGINE DRAIN, TRANSMISSION DRAIN, AXLE(S) FILL AND DRAIN
PUSH BUTTON ELECTRONIC SHIFT CONTROL, DASH MOUNTED
TRANSMISSION PROGNOSTICS - ENABLED 2013
WATER TO OIL TRANSMISSION COOLER, IN RADIATOR END TANK
TRANSMISSION OIL CHECK AND FILL WITH ELECTRONIC OIL LEVEL CHECK
SYNTHETIC TRANSMISSION FLUID (TES-295 COMPLIANT)

Fire Pump

CUSTOM DRIVELINE SPACER FOR FIRE PUMP

Front Axle and Equipment

DETROIT DA-F-12.0-3 12,000# FF1 71.5 KPI/3.74 DROP SINGLE FRONT AXLE
MERITOR 16.5X5 Q+ CAST SPIDER CAM FRONT BRAKES, DOUBLE ANCHOR, PLATINUM SHIELD FABRICATED SHOES
FIRE AND EMERGENCY SEVERE SERVICE, NON-ASBESTOS FRONT LINING
FRONT OIL SEALS
HALDEX AUTOMATIC FRONT SLACK ADJUSTERS
TRW THP-60 POWER STEERING

Front Suspension

12,000# DUAL TAPERLEAF FRONT SUSPENSION
MAINTENANCE FREE RUBBER BUSHINGS
FRONT SHOCK ABSORBERS

Rear Axle and Equipment

27,000 LB FIRE/EMERGENCY SERVICE SINGLE REAR AXLE
IRON REAR AXLE CARRIER WITH STANDARD AXLE HOUSING

MXL 17T MERITOR EXTENDED LUBE MAIN DRIVELINE WITH
HALF ROUND YOKES

MERITOR 16.5X7 P CAST SPIDER CAM REAR BRAKES,
DOUBLE ANCHOR, CAST SHOES

FIRE AND EMERGENCY SEVERE SERVICE NON-ASBESTOS
REAR BRAKE LINING

REAR OIL SEALS

HALDEX AUTOMATIC REAR SLACK ADJUSTERS

Rear Suspension

27,000# FLAT LEAF SPRING REAR SUSPENSION WITH
HELPER AND RADIUS ROD FOR FIRE/EMERGENCY

FORE/AFT CONTROL RODS

Brake System

AIR BRAKE PACKAGE

WABCO 4S/4M ABS WITH TRACTION CONTROL WITH ESC
STANDARD AIR SYSTEM PRESSURE PROTECTION SYSTEM

BW AD-9 BRAKE LINE AIR DRYER WITH HEATER

CUSTOM STEEL AIR BRAKE RESERVOIRS

BW DV-2 AUTO DRAIN VALVE WITH HEATER - WET TANK

Electrical Connections

UPGRADED CHASSIS MULTIPLEXING UNIT

UPGRADED BULKHEAD MULTIPLEXING UNIT

Wheelbase & Frame

(266 INCH) WHEELBASE / (153 INCH) CA

11/32X3-1/2X10-15/16 INCH STEEL FRAME 120KSI

(47 INCH) REAR FRAME OVERHANG

Chassis Equipment

THREE-PIECE 14 INCH CHROME STEEL BUMPER WITH
COLLAPSIBLE ENDS AND CUTOFF FOR SPEAKER

FRONT TOW HOOKS - FRAME MOUNTED

FENDER & FRONT OF HOOD MOUNTED FRONT MUDFLAPS

GRADE 8 THREADED HEX HEADED FRAME FASTENERS

Fuel Tanks

50 GALLON RECTANGULAR ALUMINUM FUEL TANK - LH

6 GALLON DIESEL EXHAUST FLUID TANK

FUEL/WATER SEPARATOR WITH WATER IN FUEL SENSOR
AND 12 VOLT PREHEATER

Tires

MICHELIN XZE2 11R22.5 14 PLY RADIAL FRONT TIRES

MICHELIN XDS 12R22.5 16 PLY RADIAL REAR TIRES

Hubs

CONMET PRESET PLUS PREMIUM IRON FRONT HUBS
CONMET PRESET PLUS PREMIUM IRON REAR HUBS

Wheels

22.5X8.25 10-HUB PILOT POLISHED ALUMINUM DISC FRONT
WHEELS
22.5X8.25 10-HUB PILOT POLISHED ALUMINUM DISC REAR
OUTER WHEELS

Cab Exterior

154 INCH BBC HIGH-ROOF ALUMINUM CONVENTIONAL AIR
RIDE CREW CAB WITH EXTERIOR SUN VISOR
NFPA COMPLIANT LH AND RH EXTERIOR GRAB HANDLES
HOOD MOUNTED CHROMED PLASTIC GRILLES
FIBERGLASS HOOD & FIREWALL INSULATION
DUAL 25 INCH ROUND STUTTER TONE HOOD MOUNTED
AIR HORNS WITH DUAL LANYARDS
DUAL ELECTRIC HORNS
LED HEADLIGHT ASSEMBLY AND INCANDESCENT
MARKER/TURN LAMP W/ CHROME BEZELS & DAYTIME
RUNNING LIGHTS
LED AERODYNAMIC MARKER LIGHTS
DUAL 102" WEST COAST BRIGHT FINISH HEATED MIRRORS
WITH LH AND RH REMOTE
LH AND RH 8 INCH BRIGHT FINISH CONVEX MIRRORS
MOUNTED UNDER PRIMARY MIRRORS
63X14 INCH TINTED REAR WINDOW
TINTED DOOR GLASS LH AND RH WITH TINTED NON-
OPERATING WING WINDOWS
RH / LH ELECTRIC POWERED WINDOWS & DOOR LOCKS
1-PIECE SOLAR GREEN GLASS WINDSHIELD
2 GALLON WINDSHIELD WASHER RESERVOIR WITHOUT
FLUID LEVEL INDICATOR, FRAME MOUNTED

Cab Interior

OPAL GRAY VINYL INTERIOR
MOLDED PLASTIC DOOR PANELS WITH ALUMINUM
KICKPLATES LOWER DOORS
BLACK MATS WITH PREMIUM INSULATION
WOODGRAIN INSTRUMENT PANELS
FORWARD ROOF MOUNTED CONSOLE WITH UPPER
STORAGE COMPARTMENTS AND ADDITIONAL CENTER
COMPARTMENT WITHOUT NETTING
IN DASH STORAGE BIN
AM/FM/WB DASH MTD RADIO WITH BLUETOOTH AND USB
AND AUXILIARY INPUTS

USB CHARGING PORTS (2) IN DASH
(2) CUP HOLDERS LH AND RH DASH
HEATER, DEFROSTER AND AIR CONDITIONER
MAIN HVAC CONTROLS WITH RECIRCULATION SWITCH
SOLID-STATE CIRCUIT PROTECTION AND FUSES
12V NEGATIVE GROUND ELECTRICAL SYSTEM
DOME LIGHT WITH 3-WAY SWITCH ACTIVATED BY LH AND
RH DOORS
(1) 12V POWER SUPPLY CHARGER IN DASH
SEATS INC 911 UNIVERSAL SERIES HIGH BACK AIR
SUSPENSION DRIVER SEAT NFPA COMPLIANT
SEATS INC 911 UNIVERSAL SERIES SCBA NON
SUSPENSION PASSENGER SEAT WITH UNDERSEAT
STORAGE NFPA COMPLIANT
SEATS INC 911 UNIVERSAL SERIES SCBA NON
SUSPENSION LH, RH AND CENTER REAR PASSENGER
SEATS WITH UNDER SEAT STORAGE NFPA COMPLIANT
GRAY VINYL SEAT COVERS WITH GRAY CORDURA CLOTH
BOLSTERS AND HEADRESTS
NFPA 1901-2009 HIGH VISIBILITY ORANGE SEAT BELTS
ADJUSTABLE TILT AND TELESCOPING STEERING COLUMN
4-SPOKE 18 INCH STEERING WHEEL
DRIVER AND PASSENGER INTERIOR SUN VISORS

Instruments & Controls

BLACK GAUGE BEZELS
LOW AIR PRESSURE INDICATOR LIGHT AND AUDIBLE
ALARM
2 INCH PRIMARY & SECONDARY AIR PRESSURE GAUGES
2 INCH ELECTRIC FUEL GAUGE
2 INCH TRANSMISSION OIL TEMPERATURE GAUGE
ENGINE COMPARTMENT MOUNTED AIR RESTRICTION
INDICATOR WITH GRADUATIONS
CUSTOM BACKUP ALARM
ELECTRONIC CRUISE CONTROL WITH SWITCHES IN LH
SWITCH PANEL
ICU3S, 132X48 DISPLAY WITH DIAGNOSTICS, 28 LED
WARNING LAMPS AND DATA LINKED
FIRE AND EMERGENCY SERVICE VEHICLES ENGINE
WARNING
ELECTRICAL ENGINE COOLANT TEMPERATURE GAUGE
ENGINE AND TRIP HOUR METERS INTEGRAL WITHIN
DRIVER DISPLAY
ELECTRIC ENGINE OIL PRESSURE GAUGE
ELECTRONIC MPH SPEEDOMETER WITH SECONDARY KPH
SCALE

ELECTRONIC 3000 RPM TACHOMETER
 IGNITION SWITCH CONTROLLED ENGINE STOP
 DIGITAL VOLTAGE DISPLAY INTEGRAL WITH DRIVER DISPLAY
 SINGLE ELECTRIC WINDSHIELD WIPER MOTOR WITH DELAY
 MARKER LIGHT SWITCH INTEGRAL WITH HEADLIGHT SWITCH
 ONE VALVE PARKING BRAKE SYSTEM WITH DASH VALVE CONTROL
 SELF CANCELING TURN SIGNAL SWITCH WITH DIMMER, WASHER/WIPER AND HAZARD IN HANDLE
 INTEGRAL ELECTRONIC TURN SIGNAL FLASHER WITH HAZARD LAMPS OVERRIDING STOP LAMPS

Paint Design

ONE SOLID CUSTOM BASE/CLEAR COAT CAB COLOR
 BLACK, HIGH SOLIDS POLYURETHANE CHASSIS PAINT

Weight Summary

	Weight Front	Weight Rear	Total Weight
Factory Weight ⁺	7988 lbs	4689 lbs	12677 lbs

(+) Weights shown are estimates only.

(***) All cost increases for major components (Engines, Transmissions, Axles, Front and Rear Tires) and government mandated requirements, tariffs, and raw material surcharges will be passed through and added to factory invoices.

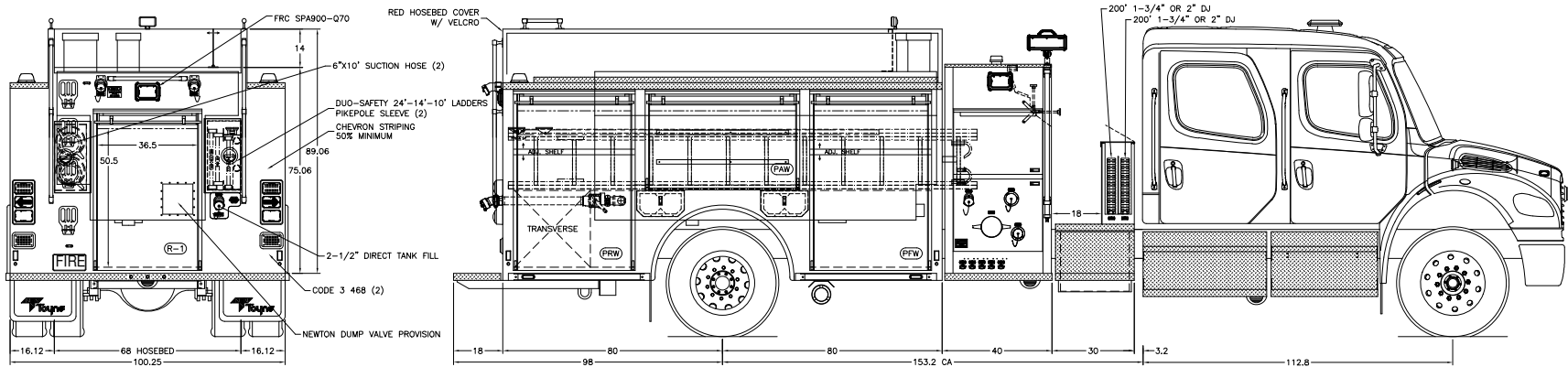

TREADBRITE TEXTURE NOT SHOWN IN TOP VIEW

REFERENCE SCALE IN INCHES

COMP.	HEIGHT	WIDTH	USABLE DEPTH		DIVIDE HEIGHT	FT
			UPPER	LOWER		
DJW	67.12	47.88	14	26	28	35.35
DAW	37.12	63.75	14	-	-	19.18
DRW	67.12	44.00	14	26	28	32.49
PFW	67.12	47.88	14	26	28	35.35
PAW	37.12	63.75	14	-	-	19.18
PRW	67.12	44.00	14	26	28	32.49
R-1	70.12	44.00	-	30	-	53.56
HOSEBED	14	68	-	14.2	-	78.23
FRONT XLAY	25.75	4.62	-	73.75	-	5.08
REAR XLAY	25.75	4.62	-	73.75	-	5.08

LOCATION TO BE DETERMINED:
SINGLE SHELF TRACK (4 COMPARTMENTS)
12" DEEP ADJUSTABLE SHELF (4)
SSBA BRACKET (2)

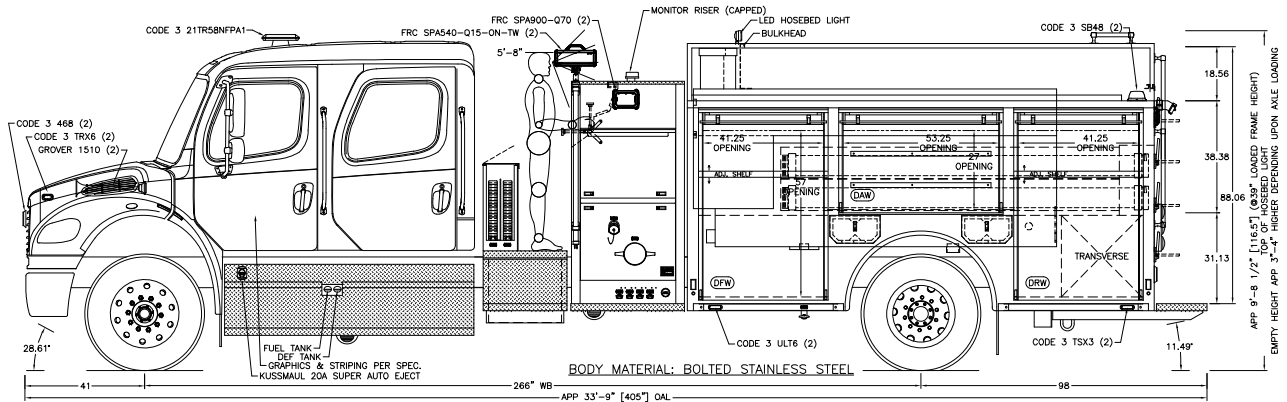
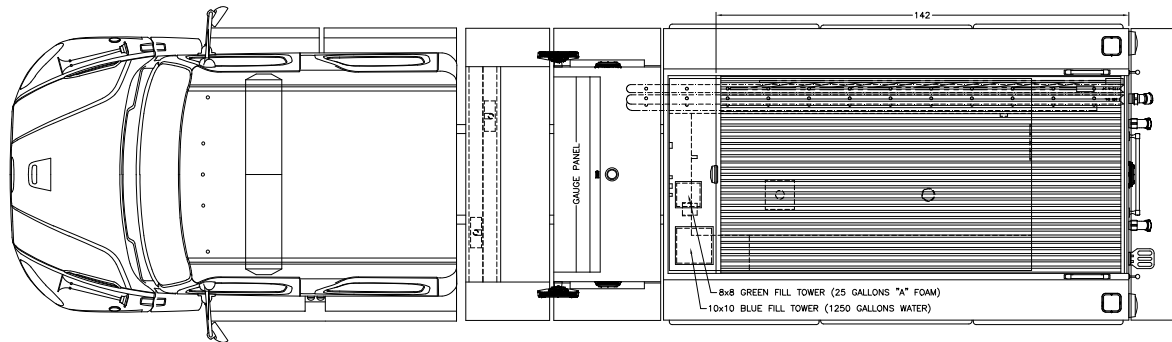

NOTE:
DIMENSIONS SHOWN ARE APPROXIMATE AND ARE SUBJECT TO MINOR CHANGE AS MAY BE FOUND NECESSARY DURING CONSTRUCTION. MINOR DETAILS MAY NOT BE SHOWN. IF DISCREPANCIES EXIST BETWEEN THIS DRAWING AND THE WRITTEN SPECIFICATIONS PROVIDED BY TOYNE, THE WRITTEN SPECIFICATIONS SHALL PREVAIL.

ORIGINAL DRAWING	28OCT19	CHASSIS:	FREIGHTLINER M2 106 4 DOOR	SCALE:	1/66	SHEET:	A
AS BUILT BEB	28APR20	WB-CA-AF:	266"-153.2"-47" D17	CITY:	---		
		BODY MATL:	BOLTED STAINLESS STEEL	STATE:	---		
		PUMP:	HALE QFLO PLUS 12500	DLR:	---		
		TANK:	1000/25 UPF POLY-TANK III	CAD:	GROSSMAN		
		FOAM SYSTEM:	N/A	DATE:	28 OCT 2019		
		GENERATOR:	N/A	FILE:	12763DEMO-A		

BREDA, IA 51436
800-648-3358
WWW.TOYNE.COM

Toyne
Built to take the call.

12763 DEMO
CUSTOM PUMPER

Toyne Inc.

CERTIFICATION OF NFPA 1901-2016 COMPLIANCE

As per NFPA 1901, the Purchaser shall assume the responsibility of determining, prior to the purchase of the apparatus, who will be responsible for ensuring that all aspects of NFPA 1901 are met. The manufacturer shall be responsible for providing or performing only the items requested by the purchaser in the documents provided to the manufacturer by the purchaser.

Written certification shall be provided by the manufacturer stating that the delivered apparatus complies with the NFPA 1901 Standard. If the purchaser has elected to provide, perform, outsource and/or contract with a third party or waive any item required by NFPA 1901, the manufacturer shall provide, upon delivery, a "Statement of Exceptions" per Chapter 4 of NFPA 1901 4.21.

The "Statement of Exceptions" shall include:

- A separate specification of the section of the NFPA Standard for which the apparatus is lacking compliance.
- A description of the particular aspect of the apparatus that is not compliant therewith or required equipment that is missing.
- A description of the further changes or modifications to the delivered apparatus which must be completed to achieve full compliance.
- An identification of the entity that will be responsible for making the necessary post-delivery changes or modifications or for supplying and installing any missing required equipment to the apparatus to achieve full compliance to the standard.

Prior to, or at the time of, delivery of the apparatus, the Statement of Exceptions shall be signed by an authorized agent of the entity responsible for the final assembly of the apparatus and by an authorized agent of the purchasing entity, indicating a mutual understanding and agreement between the parties regarding the substance thereof.

The purchaser shall not place the apparatus into active emergency service until fully compliant with NFPA 1901.

NFPA REQUIRED EQUIPMENT

The end user of this apparatus shall provide all other equipment and accessories that are required by NFPA 1901 but not specifically listed in these specifications.

MAXIMUM TOP SPEED

The maximum top speed of this apparatus shall be determined using the following NFPA 1901 Chapter 4 criteria:

- Apparatus with 1250 gallon combined water tank capacity shall not exceed 60 MPH.
- Apparatus with GVWR of over 50,000 lbs. shall not exceed 60 MPH.
- Apparatus weighing over 26,000 lbs. shall not exceed 68 MPH.

HALE MODEL Q-FLO-PLUS 1,250 GPM SINGLE STAGE PUMP

The fire pump shall be a Hale Fire Pump Company Q-FLO-PLUS that complies with all applicable requirements of the latest edition of NFPA 1901, "Standard for Automotive Fire Apparatus" published by the National Fire Protection Association.

PUMP WARRANTY

Toyne Inc.

The pump shall be covered by the Hale Pro-Tech 5-year pump warranty against workmanship and materials. Both parts and labor shall be covered for the first 2 years and years 3-5 shall have parts only coverage.

UNDERWRITER'S LABORATORY CERTIFICATION

The completed apparatus shall be tested and approved by the independent testing company Underwriter's Laboratories, Inc. The manufacturer of the apparatus shall be responsible for all costs involved in this test. The certification of inspection and approval shall be presented to the Fire Chief of the Department upon delivery of the completed apparatus.

PUMP PERFORMANCE - 1,250 U.S. GPM.

The pump shall be a single stage centrifugal with a class "A" rated capacity of 1,250 United States gallons per minute. The pump shall deliver the percentage of rated discharge pressures as indicated below:

- 100 percent of rated capacity at 150 pounds net pressure.
- 70 percent of rated capacity at 200 pounds net pressure.
- 50 percent of rated capacity at 250 pounds net pressure.
- 100 percent of rated capacity at 165 pounds net pressure.

PUMP CONSTRUCTION

The pump shall be driven by a drive line from the truck transmission. The pump shall be free from objectionable pulsation and vibration under all normal operating conditions. The engine shall provide sufficient horsepower and revolutions per minute to allow the pump to meet or exceed its rated performance.

The pump suction and discharge passages shall be hydrostatically tested to a pressure of 500-PSI. The pump shall be fully tested at the pump manufacturer's factory to the performance spots as outlined by NFPA 1901.

The pump body and related parts shall be of fine grain alloy cast iron with a minimum tensile strength of 30,000 PSI. All moving parts in contact with water shall be of high quality bronze or stainless steel. Pumps utilizing castings made of lower tensile strength cast iron are not acceptable.

The pump body shall be horizontally split on a single plane in two sections for easy removal of entire impeller assembly including wear rings and bearings from beneath the pump without disturbing piping or the mounting of the pump on the chassis.

The pump shaft to be rigidly supported by three bearings for minimum deflection. The bearings shall be heavy-duty deep groove style bearings in the gearbox and they shall be splash lubricated.

The pump impeller shall be of hard, fine grain bronze with a mixed flow design; accurately machined, hand ground, and individually balanced. The vanes of the impeller intake eyes shall be hand ground and polished to a sharp edge, and shall be of sufficient size and design to provide ample reserve capacity utilizing minimum horsepower.

The pump shaft shall be fabricated of heat-treated, electric furnace, corrosion resistant stainless steel, and shall be super finished under the shaft seal. The pump shaft must be sealed with double lip oil seal to keep road dirt and water out of gearbox.

GEAR BOX

Toyne Inc.

The gear box shall be completely manufactured and tested at the pump manufacturer's factory.

The pump gearbox shall be of sufficient size to withstand up to 16,000 lbs. ft. of torque of the engine in both road and pump operating conditions. The gearbox shall be designed of ample capacity for lubrication reserve and to maintain the proper operating temperature.

The gearbox drive shafts shall be of heat-treated chrome nickel steel and shall be a minimum of 2.75 inches in diameter, on both the input and the output drives shafts. The gearbox shall withstand the full torque of the engine in both road and pump operating conditions.

All gears, both drive and pump, shall be of highest quality electric furnace chrome nickel steel. Bores shall be ground to size and the gear teeth shall be crown shaven, and hardened for smooth, quiet running, and a higher load carrying capability. An accurately cut spur design shall be provided to eliminate all possible end thrust.

The pump gear ratio shall be selected by the apparatus manufacturer to give the maximum performance with the engine and transmission selected.

NFPA 2016 INTERLOCK MOULE

An interlock module shall be provided on the pump shift to comply with NFPA shift safety requirements.

MECHANICAL SEAL

The pump shaft shall be equipped with a single mechanical type seal on the suction (inboard) side of the pump. The mechanical seal shall be a minimum of two inches in diameter and shall be spring loaded, maintenance free and self-adjusting. The mechanical seal shall be constructed of a carbon sealing ring, stainless steel coil spring, Viton rubber cup, and a tungsten carbide seat with Teflon backup seal.

FRC PUMP BOSS PRESSURE GOVERNOR SYSTEM

Fire Research Pump Boss pressure governor and monitoring display kit shall be installed. The kit shall include a control module, pressure sensor, and cables.

The following continuous displays shall be provided:

- Check engine/stop engine warning lights
- Engine RPM; shown with four daylight bright LED digits more than 1/2" high
- Engine oil pressure shown on an LED bar graph display in 10 psi increments
- Engine temperature shown on an LED bar graph display in 10 degree increments
- Battery voltage shown on an LED bar graph display in 0.5 volt increments
- PSI / RPM setting; shown on a dot matrix message display
- PSI and RPM mode LEDs
- Throttle ready light.

A dot-matrix message display shall show diagnostic and warning messages as they occur. It shall show monitored

Toyne Inc.

apparatus information, stored data, and program options when selected by the operator.

The program shall store the accumulated operating hours for the pump and engine, previous incident hours, and current incident hours in a non-volatile memory. Stored elapsed hours shall be displayed at the push of a button. It shall monitor inputs and support audible and visual warning alarms for the following conditions:

- High Engine RPM
- Pump Overheat
- High Transmission Temperature
- Low Battery Voltage (Engine Off)
- Low Battery Voltage (Engine Running)
- High Battery Voltage
- Low Engine Oil Pressure
- High Engine Coolant Temperature

The governor shall operate in two control modes, pressure and RPM. No discharge pressure or engine RPM variation shall occur when switching between modes. A control knob that uses optical technology shall adjust pressure or RPM settings. It shall be 2" in diameter with no mechanical stops, a serrated grip, and have a red idle push button in the center.

A throttle ready LED shall light when the interlock signal is recognized. The governor shall start in pressure mode and set the engine RPM to idle. In pressure mode the governor shall automatically regulate the discharge pressure at the level set by the operator. In RPM mode the governor shall maintain the engine RPM at the level set by the operator except in the event of a discharge pressure increase. The governor shall limit a discharge pressure increase in RPM mode to a maximum of 30 psi. Other safety features shall include recognition of no water conditions with an automatic programmed response and a push button to return the engine to idle.

TFT A-18 INTAKE RELIEF VALVE

A TFT model A-18 intake relief/dump valve shall be provided on the intake side of the pump to relieve excess incoming pressure. The system shall be designed to automatically restore to a non-relieving position when excessive pressure is no longer present. The pressure adjustment range shall be from 50 psi to 200 psi. The relief system shall be adjustable with a common type box end wrench.

The intake relief valve shall be pre-set to 125 psi.

PUMP SHIFT MECHANISM -AIR/ELECTRIC

The pump shall be shifted from road to pump by means of a cab mounted air over electric pump shift switch. The switch shall have a built in positive locking mechanism to prevent accidental movement of the switch. The locking mechanism shall require the operator to manually lift up on the switch lever to disengage the lock.

The switch shall have three positions:

- Position 1 = road position
- Position 2 = neutral position
- Position 3 = pump position

Toyne Inc.

A green indicator light shall be provided in the driving compartment and shall be energized when the pump shift has been completed. This light shall be labeled "PUMP ENGAGED".

When the apparatus is equipped with an automatic transmission, a green indicator light shall be provided in the driver's compartment. It shall be energized when both the pump shift has been completed and the chassis transmission is in pump gear. This light shall be labeled "OK TO PUMP".

TRIDENT PRIMING SYSTEM

A Trident air priming system shall be provided.

MANIFOLD DRAIN VALVE

The pump shall have a manifold type drain valve assembly consisting of a stainless steel plunger in a bronze body with multiple ports. The control for the valve shall be on the left side along the bottom of the panel and above the side running board. The valve shall be a rotary type with a large easy to grip handle. The valve shall be labeled "PUMP DRAIN".

ICI "LEVER LIFT" BLEEDER/DRAIN VALVES

ICI 3/4" quarter turn ball type bleeder/drain valve shall be provided for each discharge and auxiliary intake. A hose shall be connected to the valve that will direct water below the apparatus and away from the immediate pump operator's location.

The control handle shall be "lever lift" style for easy actuation. The handle for the control shall have a recessed area for the color coded identification label.

LOW POINT AUTO-DRAINS

Automatic drains shall be provided in low points of any discharge piping. The drain shall drain to the ground below its location. This drain shall be a supplementary drain and will not be considered the required 3/4" bleeder drain.

6" LEFT (DRIVER) SIDE MASTER INTAKE

A 6" master intake shall be provided on the left (driver) side of the apparatus. The intake shall have a 6" male NST connection. The intake shall have a removable screen to prevent the entry of large objects into the pump. The screen shall be constructed of a material that will provide cathodic protection to the pump. A label shall be provided above the intake that states "DRIVER SIDE MASTER INTAKE". The label shall be color coded burgundy.

LEFT SIDE MASTER INTAKE CAP

A 6" FNST LH chrome cap shall be provided on the left side master intake.

6" RIGHT (PASSENGER) SIDE MASTER INTAKE

A 6" master intake shall be provided on the right (passenger) side of the apparatus. The intake shall have a 6" male NST connection. The intake shall have a removable screen to prevent the entry of large objects into the pump. The screen shall be constructed of a material that will provide cathodic protection to the pump. A label shall be provided above the intake that states "PASSENGER SIDE MASTER INTAKE". The label shall be color coded burgundy.

Toyne Inc.

RIGHT SIDE MASTER INTAKE CAP

A 6" FNST LH chrome cap shall be provided on the right side master intake.

THERMAL RELIEF VALVE

A thermal relief valve shall be provided and installed on the discharge side of the pump. The valve shall function automatically when the water temperature in the pump exceeds 120 degrees Fahrenheit. The valve shall discharge a 3/8" stream of water to booster tank thereby preventing pump overheating. The valve shall be self-resetting after the temperature of the water in the pump drops below 120 degrees Fahrenheit.

TANK REFILL/RECIRCULATION DISCHARGE

A discharge shall be provided from the pump discharge manifold to allow pump cooling when necessary as well as to refill the booster tank.

The water tank fill gauge shall be directly in line with this discharge control.

The valve and piping shall be 2".

The refill/recirculation discharge shall be manually controlled on the pump panel.

STAINLESS STEEL PIPING

All piping for discharges shall be stainless steel using stainless steel fittings. High pressure helix wire reinforced flexible piping with a minimum burst pressure of 1200 psi may be used in some areas to minimize friction losses. All flexible piping couplings shall be high tensile strength stainless steel.

All piping shall be properly supported and braced to prevent movement of piping other than what is allowed by the flexible couplings to compensate for apparatus flexing.

Any discharge manifolds provided on the apparatus must be fabricated of a minimum of schedule 10 304 marine grade piping. Use of any welded light gauge (less than Schedule 10) manifolding or plumbing will not be acceptable.

The stainless steel piping shall be warranted to be free from corrosion perforation for a period of 10 years following the delivery of the apparatus.

VICTAULIC COUPLINGS

Victaulic style couplings shall be used in the assembly of the pump piping system. The couplings shall allow flex in the piping and provide for a disassembly point for maintenance and repairs.

VENTED LUG CAPS AND PLUGS

All intake and discharge plugs and caps and plugs shall be vented lug type designed to relieve trapped pressure and help reduce possible operator injuries.

Toyne Inc.

AKRON HD-8800 SERIES VALVES

All discharge and small diameter auxiliary intakes shall have heavy duty Akron 8800 series brass ball valves with stainless steel ball. This shall include the tank to pump and tank fill valve.

RIGHT SIDE FORWARD AUXILIARY INTAKE

An auxiliary intake shall be provided on the right side of the pump compartment in the forward position.

The valve shall be manually controlled from the pump operator's position.

The intake shall have a 2 1/2" chrome plated female NST swivel connection with screen and a male NST chrome plated intake plug and chain.

A 3/4" bleeder/drain valve shall be provided.

FUTURE FOAM CAPABILITIES

The apparatus shall be pre-piped for future installation of a foam system.

The foam manifold shall be stainless steel. This manifold shall be fed from the main pump discharge manifold and shall have a spacer pipe installed between the two manifolds with victaulic couplings on each end. The spacer pipe shall be the length required for future installation of an electronic foam system.

To minimize the future costs of installing foam on the apparatus, there shall be no exception to this requirement.

The following discharges shall be foam capable:

Two 1 3/4" crosslays.

Right rear 2 1/2" discharge.

RIGHT SIDE DISCHARGES

One 2 1/2" discharge and one 3" discharge shall be provided on the right side pump panel. The 3" discharge shall be located forward of the intake and the 2 1/2" shall be located rear of the intake.

One (1) right side 2 1/2" discharge(s):

The right side 2 1/2" discharge shall be manually controlled on the pump panel.

The discharge shall be equipped with a chrome plated brass or bright finish stainless steel discharge elbow with 2 1/2" MNST thread.

A 2 1/2" chrome plated NST cap and chain shall be provided.

One (1) right side 3" discharge(s):

Toyne Inc.

The right side 3" discharge shall be manually controlled on the pump panel. The control shall have an integrated slow closing mechanism to comply with NFPA 1901.

The discharge shall extend straight out of the apparatus with no elbow.

A 3" chrome plated NST cap with chain shall be provided.

A 3" chrome plated NST cap with chain shall be provided.

LEFT SIDE DISCHARGE

One 2 1/2" discharge shall be provided on the left side pump panel. The discharge shall be located forward of the intake.

One (1) left side 2 1/2" discharge(s):

The left side 2 1/2" discharge shall be manually controlled on the pump panel.

The discharge shall be equipped with a chrome plated brass or bright finish stainless steel discharge elbow with MNST thread.

A 2 1/2" chrome plated NST cap and chain shall be provided.

RIGHT REAR 2 1/2" DISCHARGE

One (1) 2 1/2" discharge shall be provided on the right rear of the apparatus.

The valve shall be manually controlled on the pump panel.

A chrome discharge elbow shall be provided with 2 1/2" NST threads.

The discharge shall be used as a pre-connected line and shall not require any cap or chain.

LEFT REAR 2 1/2" DISCHARGE

One (1) 2 1/2" discharge shall be provided on the left rear of the apparatus.

The valve shall be manually controlled on the pump panel.

A chrome discharge elbow shall be provided with 2 1/2" NST threads.

The discharge shall be used as a pre-connected line and shall not require any cap or chain.

The discharge shall be used as a pre-connected line and shall not require any cap or chain.

1 3/4" LOW MOUNT CROSSLAY PRECONNECTS

Two 1 3/4" preconnected crosslays shall be provided and located between the chassis cab and the top mounted operator's walkway standing position.

Toyne Inc.

The crosslay compartment shall be constructed of 5052 smooth aluminum sheet material with a random brushed finish applied after fabrication. Each crosslay shall be piped using 2" piping or high pressure hose incorporating a 2" valve with the control on the top mount pump operator's panel.

An aluminum treadbrite full length hinged cover shall be provided on the top of the crosslay compartment. Rubber spacer blocks shall be provided on the back of the cab to keep the cover from contacting the cab when the cover is in the raised position.

The #1 - hand line crosslay shall have the capacity to hold 200' of 1 3/4" or 2" fire hose and nozzle.

The #2 - hand line crosslay shall have the capacity to hold 200' of 1 3/4" or 2" fire hose and nozzle.

The valve(s) shall be manually controlled on the pump panel.

There shall be two (2) 2" swivel elbows with 1 1/2" male NST hose thread connections provided on the cross lay hose beds. The swivels shall be mounted in a position to prevent hose "pinching" at the hose thread connection.

3/4" manual drain valves shall be provided for all 1 3/4" crosslays. The valves shall have an all brass body with heavy duty neoprene seal.

CROSSLAY COMPARTMENT ENDS - BLACK WEBBING

The crosslay compartment shall be enclosed on each end using a heavy duty webbing to prevent hose from accidentally unloading. The webbing shall be black.

A yellow nozzle strap shall be provided for each crosslay. The strap shall be designed to loop through the nozzle handle and secured to the apparatus to keep nozzle from coming out of the crosslay compartment without manually disconnecting the nozzle strap.

The crosslay/speedlay end cover shall be secured with footman loops and velcro straps.

3" MONITOR DISCHARGE

A 3" monitor discharge shall be provided above the pump compartment. The discharge piping shall extend above the pump compartment a sufficient distance to allow use of the deck gun.

The valve shall be manually controlled on the pump panel. The control shall have an integrated slow closing mechanism to comply with NFPA 1901.

PUMP COMPARTMENT

A modular pump compartment with top mounted pump operator's panel shall be provided. The modular design of the pump compartment shall allow the compartment to be fully independent of the apparatus body. A 1" flex joint shall be provided between the pump compartment and the apparatus body.

The modular design of the pump compartment shall allow the entire pump system, including the pump itself, to be removed from the apparatus in a one-piece assembly while leaving the body intact and without having to cut any sheet

Toyne Inc.

metal or welds.

STAINLESS STEEL PUMP COMPARTMENT CONSTRUCTION

The entire pump compartment shall be constructed using only 304 marine grade stainless steel fabricated sheeting with a #4 annealed and polished finish on all exterior surfaces. The pump compartment shall not require any finish painting. Due to the extreme twisting and flexing that all fire apparatus are subjected to, aluminum shall not be used in any portion of the pump compartment structural support. The use of any type of enclosed tubing that requires the use of self-tapping or any other type of machine screw shall not be acceptable.

PUMP COMPARTMENT WIDTH – 44”

The pump compartment shall be 44” from the forward wall to the rear wall.

TOP MOUNT PUMP OPERATOR'S WALKWAY

An 18" wide (front to rear) pump operator's walkway shall be provided between the pump compartment and the chassis cab. A 1" minimum space shall be provided between the walkway edges, pump compartment and rear wall of the chassis.

TOP MOUNT WALKWAY LIGHTING – LED

Two teardrop style LED lights shall be provided to illuminate the top mount walkway area.

WALKWAY COMPARTMENT - DRIVER'S SIDE

A compartment shall be incorporated into the walkway assembly on the driver's side of the apparatus. The compartment shall have a minimum depth of 22", and shall be a minimum of 24" wide x 18" high in the rear 13" and no less than 6" high in the forward section.

The entire step and running board assembly shall be horizontally hinged to allow complete access to the compartment. A pneumatic spring hold-open device shall be provided to hold the integrated step/door assembly open.

WALKWAY COMPARTMENT - OFFICER'S SIDE

A compartment shall be incorporated into the walkway assembly on the officer's side of the apparatus. The compartment shall have a minimum depth of 22", and shall be a minimum of 24" wide x 18" high in the rear 13" and no less than 6" high in the forward section.

The entire step and running board assembly shall be horizontally hinged to allow complete access to the compartment. A pneumatic spring hold-open device shall be provided to hold the integrated step/door assembly open.

(The right side walkway compartment dimensions may be effected by the chassis exhaust system design.)

WALKWAY COMPARTMENT FLOOR

The walkway compartment floors shall have Turtle Tile floor tiles.

WALKWAY COMPARTMENT LIGHTING – LED

Toyne Inc.

An LED strip light shall be provided in the under walkway compartment(s). The light(s) shall be activated by the pump panel light switch.

INTERMEDIATE WALKWAY ACCESS STEPS

Intermediate steps shall be provided on each side of the walkway, positioned between the walkway surface and the 'runningboard' height step. The steps shall be constructed of NFPA aluminum treadbrite.

TOP MOUNT PUMP OPERATOR'S WALKWAY MATERIAL

The entire pump operator's walkway assembly shall be constructed of NFPA compliant slip resistant aluminum treadbrite on all stepping surfaces.

PUMP COMPARTMENT RUNNING BOARDS

The pump compartment side running boards shall be constructed of NFPA compliant slip resistant aluminum treadbrite.

PUMP COMPARTMENT FRONT WALL

The front wall of the pump compartment shall be constructed of aluminum treadbrite which is bolted to the pump compartment assembly and removable.

PUMP COMPARTMENT SIDE ACCESS DOORS - TOP MOUNT

A brushed stainless steel hinged access door shall be provided on each side of the pump compartment. The doors shall be horizontally hinged and have pneumatic hold open devices and push button type flush latches. The doors shall be a minimum of 30" wide x 20" high.

TOP MOUNT BRUSHED STAINLESS STEEL PUMP PANEL

A rear facing top mounted pump panel shall be provided to allow simple, efficient operation of all pump functions necessary during normal operations.

A dual level inclined pump panel shall be provided for convenient user friendly layout of the panel to simplify the operation of the apparatus. Both levels of the panel shall be sloped to provide an angled view of the panel so that the operator may read all identification labels easily.

All controls for the pump shall be identified using permanently engraved identification labels properly secured to the panel. All discharge and intake identification labels shall be color coded to NFPA 1901 recommendations with labels at the control, intake/discharge location and drain port location.

The front incline panel shall be constructed of brushed stainless steel and shall begin at the lower edge of the front panel just behind the control levers and continue back to the area which the second incline level begins.

The rear incline panel shall be constructed of brushed stainless steel and shall begin just above the pressure gauge mounting area and continue up to the top of the pump compartment. The panel shall have a full width stainless steel hinge

Toyne Inc.

at the bottom to allow the panel to hinge forward for access to the back of the panel. A latch shall be provided on each end to secure the panel in the closed position. A full pump panel width brushed stainless steel light shield shall be provided at the top of the gauge panel.

SIDE INTAKE/DISCHARGE PANELS - TOP MOUNT

The side panels of the pump compartment shall be constructed of brushed stainless steel. The side panels shall be easily removable and held into place using stainless steel or chrome plated flush mounted latches.

Panels that are permanently attached to the pump compartment or require removal of mechanical fasteners are not acceptable.

LED PUMP PANEL LIGHTS

The top mount pump panel shall be illuminated using a track type LED light assembly.

The light shall be constructed of an unbreakable type clear poly flexible material housed in an aluminum extrusion mounted behind a brushed stainless steel light shield shall be provided across the top of the gauge panel.

LED SIDE DISCHARGE/INTAKE PANEL LIGHTS

The right and left side discharge and intake panels shall be illuminated using a track type LED light assembly on each side.

The lights shall be constructed of an unbreakable type clear poly flexible material housed in an aluminum extrusion mounted behind a brushed stainless steel light shield provided across the top of the gauge panel.

AUTOMATIC PUMP PANEL LIGHT ACTIVATION

The pump panel lights above the pump control panel shall function automatically with the pump shift activation.

INNOVATIVE CONTROLS TOP MOUNT CONTROL HANDLES

All top mount valve control handles shall be Innovative Controls 'locking' lever type with "T" handles. The "T" handles shall be chrome plated zinc and shall have a recessed area for the color coded identification label.

VALVE CONTROL LINKAGES

All manual valve controls requiring remote actuation shall have control rod linkages constructed of 1/2" galvanized pipe and shall implement heavy ball swivel joints and clevises for smooth valve operation.

ICI MASTER PUMP DISCHARGE PRESSURE GAUGE

Toyne Inc.

An ICI 4" diameter master pressure gauge shall be provided to indicate the main pump discharge pressure. The gauge shall read from 30" hg vacuum to 400 psi and shall be accurate within +/- 1%. The gauge shall be glycerin filled (-40F to +150F) and have a high impact resistant clear acrylic lens.

ICI MASTER PUMP INTAKE PRESSURE GAUGE

An ICI 4" diameter master pressure gauge shall be provided to indicate the pump intake pressure. The gauge shall read from 30" hg vacuum to 400 psi and shall be accurate within +/- 1%. The gauge shall be glycerin filled (-40F to +150F), read up to 400 psi, be accurate within +/- 1% and have a high impact resistant clear acrylic lens.

The master intake and discharge gauges shall have bright finish stainless steel bezels.

The master gauge dials shall be white with black markings. The needle shall match the color of the markings.

The master intake gauge shall be clearly labeled "PUMP INTAKE" and shall be located to the left of the master discharge pressure gauge. The label shall be burgundy color.

The master discharge gauge shall be clearly labeled "PUMP DISCHARGE" and shall be located to the right of the intake pressure gauge. The label shall be black color.

The master intake/discharge pressure gauges shall have a lifetime non-yellowing and freeze warranty. The gauges shall also be warrantied for 4 years for defects in materials and workmanship, including fluid leakage. The warranty will not cover labor costs and/or transportation costs.

PRESSURE/VACUUM TEST PLUGS

Underwriter's test plug adapters shall be provided for connection of pump test gauges.

INNOVATIVE CONTROLS SL PLUS TANK GAUGE - PUMP PANEL

An Innovative Controls model SL Plus tank gauge shall be provided on the pump panel. The gauge shall feature a 180 degree highly visible wide view ultra-bright LED display showing the level of the booster tank.

TANK GAUGE PARK BRAKE DISABLE

The tank gauge(s) shall be disabled when the park brake is released so that the lights are not a distraction when the vehicle is in motion.

ICI DISCHARGE PRESSURE GAUGES

Unless otherwise specified, each 1 1/2" or larger discharge shall have an ICI pressure gauge. The gauge shall be glycerin filled (-40F to +150F), read from 0 - 400 psi, be accurate within +/- 1% and have a high impact resistant clear acrylic lens.

The individual discharge pressure gauges shall have a 2 3/4" diameter.

The discharge pressure gauge dials shall be white with black markings. The needle shall match the color of the markings.

Toyne Inc.

The pressure gauge shall be directly in line with or adjacent to the discharge control handle for the discharge that they provide pressure readout for. **For ease of operation, this requirement must be strictly adhered to. There shall be no exception to this requirement.**

The gauges shall be clearly labeled with permanent color coded labels.

The discharge pressure gauges shall have a lifetime non-yellowing and freeze warranty. The gauge shall also be warrantied for four years for defects in materials and workmanship including fluid leakage. Warranty will not cover labor costs and/or transportation costs.

IDENTIFICATION LABELS FOR PUMP PANEL

Innovative Controls verbiage label bezels shall be installed. The bezel assemblies will be used to identify apparatus components. These labels shall be designed and manufactured to withstand the specified apparatus service environment.

Where required, the verbiage label bezel assemblies shall include a chrome plated panel mount bezel with durable easy to read UV resistant polycarbonate inserts featuring the specified verbiage and color coding. The UV resistant polycarbonate verbiage and color inserts shall be sub-surface screen printed to eliminate the possibility of wear and protect the inks from fading. Both the insert labels and bezel shall be backed with 3M permanent adhesive (200MP), which meets UL969 and NFPA standards.

The color scheme for the discharge and intake labels shall be per NFPA A.16.9.1

1,200 GALLON BOOSTER TANK

The tank shall have the capacity of 1,200 U.S. gallons and shall have a LIFETIME warranty provided by the manufacturer of the tank.

The tank shall be constructed of 1/2" thick polypropylene sheet stock. This material shall be non-corrosive stress relieved thermoplastic U.V. stabilized for maximum protection. The booster tank shall be of a specific configuration and is so designed to be completely independent of the body and compartments. All joints and seams shall be nitrogen welded and tested for maximum strength and integrity. The top of the booster tank is fitted with removable lifting eyes designed with a 3 to 1 safety factor to facilitate easy removal.

The transverse swash partitions shall be manufactured of 3/8" polypropylene material. The longitudinal swash partitions shall be constructed of 3/8" polypropylene and extend through the cover to allow for positive welding and maximum integrity. All partitions shall be equipped with vent and air holes to permit movement of air and water between compartments. The partitions shall be de-signed to provide maximum water flow. All swash partitions shall interlock with one another and are welded to each other as well as to the walls of the tank.

The tank shall have a combination vent and manual fill tower. The fill tower shall be constructed of 1/2" polypropylene and shall be a minimum dimension of **10" x 10"** outer dimension. The tower shall be located in the left front corner of the hosebed. The tower shall have a 1/4" thick remov-able polypropylene screen and polypropylene hinged type cover. The vent overflow shall be a mi-nimum of schedule 40 polypropylene pipe with a minimum I.D. of 4" that is designed to run through the tank and shall be piped behind the rear wheels to maximize traction.

The tank cover shall be constructed of 1/2" thick polypropylene stress relieved, UV stabilized ma-terial and shall incorporate a three piece locking design which will allow for individual removal of each section of necessary. The tank cover shall be recessed 3/8" from the top of the tank and shall be welded to both sides and longitudinal partitions of maximum integrity. Each of the covers shall have hold downs consisting of 2" polypropylene dowels spaced a maxi-mum

Toyne Inc.

of 30" apart. These dowels shall extend through the covers and will assist in keeping the covers rigid under fast filling conditions. A minimum of two lifting dowels shall be drilled and tapped to accommodate the lifting eyes.

The sump shall be constructed of 1/2" polypropylene. The sump shall have a 3" NPT threaded outlet on the bottom for a drain plug. An anti-swirl plate shall be located approximately 2 1/2" above the sump.

The tank cradle assembly shall be designed to provide support to the tank. The assembly shall be approved by the manufacturer of the tank.

1" TANK SUMP DRAIN

A 1" drain shall be provided in the bottom of the tank sump to fully drain the tank. The drain shall use 1" stainless steel piping with a 1" valve. The control for the valve shall be removed to the driver's side of the apparatus just under and behind the side rub rail. The drain control handle shall be labeled "TANK DRAIN".

3" TANK SUMP CLEAN OUT PLUG

A 3" tank sump clean out plug shall be provided in the bottom of the tank sump.

25 GALLON CLASS A FOAM TANK

A 25 gallon Class A foam tank shall be provided. The tank shall have all connections necessary to connect to the foam system and shall also have a 1/4 turn drain valve with hose attached to allow the tank to be drained.

The tank shall have an **8" x 8"** fill tower with hinged type lid with latch. A vent shall be provided in the lid.

A label shall be provided on the lid that reads "CLASS A FOAM TANK FILL" and "WARNING: DO NOT MIX BRANDS OR TYPES OF FOAM".

CLASS A FOAM TANK/BOOSTER TANK INTEGRATION

The class A foam tank shall be integrated into the apparatus booster tank. The foam tank shall not be separate from the booster tank.

FUTURE DUMP VALVE MOUNTING

The booster tank shall be prepped for the future installation of a 10" Newton dump valve. Markings shall be provided on the surface of the tank for the cutout as well as the bolt hole pattern.

A cutout shall be provided in the rear compartment/rear face wall. A sealed cover plate shall be provided.

2 1/2" REAR TANK FILL

One 2 1/2" rear tank fills shall be provided on the rear of the apparatus. The fill connection shall be located on the right side of the rear face. The valve shall be located on the inside of the rear compartment with the valve control and connection located on the exterior. The fill valve shall be connected to the tank with 2-1/2" stainless steel threaded pipe, with the hose connection on the exterior of the apparatus supplied with a 2 1/2" FNST swivel connection, 30-degree elbow with a chrome plated plug and chain.

Toyne Inc.

An Akron 8825 series valve with R-1 handle shall be utilized on the tank fill. The control for the valve and the valve bleeder/drain control shall be remoted to the exterior of the rear compartment.

3" TANK TO PUMP

A 3" tank to pump line and valve shall be provided between the tank and the pump.

The tank to pump valve shall be manually controlled on the pump panel.

TANK TO PUMP CHECK VALVE

A check valve assembly shall be provided on the pump. The valve shall prevent unintentional back filling of the tank through the tank to pump line. Connection from the valve to the tank shall be made by using a non-collapsible flexible rubber hose.

HOT DIPPED GALVANIZED SUB FRAME

The tank cradle and body substructure shall be constructed of high strength ASTM A-36 structural steel with 36,000 psi minimum yield strength. The entire substructure shall be framed and jig welded together to insure a truly square assembly. The substructure shall be fastened to the chassis rails so that it may be easily removed from the chassis for repair, replacement or mounting to a new chassis.

After complete assembly of the tank cradle substructure, the entire assembly shall be hot dipped galvanized for superior corrosion protection.

Due to the extreme duty that this apparatus will experience during its intended service life and to prevent rusting and corrosion from shortening the service life of this apparatus, sub frames fabricated of painted/undercoated steel or aluminum tubing shall not be acceptable.

20 YEAR SUB-STRUCTURE WARRANTY

The tank cradle and body substructure shall have a 20 warranty covering failure due to corrosion perforation or structural design error.

This warranty shall be in effect for 20 years after delivery of the apparatus to the customer. **NO EXCEPTION.**

HYPER-FLEX BODY MOUNTING

The body module assembly shall be mounted to the chassis frame rails with "*Hyper-Flex*" vibration and shock isolators using a forward mounting system. Flexible neoprene pads, or U-springs especially developed for the expected weight and torsional flexing of the apparatus body, shall be incorporated into the system to eliminate chassis frame rail flex from transmitting harmful loads and twisting onto the body.

APPARATUS BODY MATERIAL

The entire apparatus body shall be constructed of 304 marine grade stainless steel with a #4 annealed and polished finish. The interior of the apparatus body shall not require any finish painting. The compartment interiors must be a #4 finish. Mill finish or DA sanded finish will not be acceptable.

Toyne Inc.

APPARATUS BODY CONSTRUCTION

The entire apparatus body shall be formed by sheering and bending the sheet metal. Metal tubular structures or extrusions shall not be used in the construction of the apparatus body. All edges of the sheared metal shall be sanded to remove any sharp sheering edges prior to bending the metal. After sheering and bending, the body shall be assembled on a jig table that is designed to hold all parts securely in place to insure an accurately built apparatus body.

APPARATUS BODY ASSEMBLY METHOD

The entire apparatus body shall be assembled using only bolted type construction. All apparatus body parts shall be able to be unbolted without the need to cut welds, etc. No exceptions to this requirement as all apparatus manufacturers have the capability to manufacture apparatus bodies in this manner.

COMPARTMENT FLOORS

All compartment floors shall be constructed of 304 marine grade stainless steel with a # 4 annealed and polished finish on the interior surface. The drain ports shall be designed to prevent road spray from entering the compartment. The front edge shall consist of a minimum of two bends to provide additional strength in the compartment floor and shall then form the lower door jamb.

All compartment floors shall be sweep out design. This shall include the lower side compartments, any compartments above the wheel well, any transverse compartments, and the rear face compartment(s). Any exception to this requirement will cause immediate rejection of bid.

INTERIOR COMPARTMENT SURFACES

All visible interior compartment surfaces shall be 304 marine grade stainless steel with a # 4 annealed and polished finish. Surfaces that are painted or coated in any manner, raw material or any surface with any type sanded finish are not acceptable.

FRONT COMPARTMENT CORNERS

The apparatus body front compartment corners and vertical faces on both sides shall be constructed of 304 marine grade stainless steel with a # 4 annealed and polished finish. The corners shall be a one-piece fabrication from top to bottom and from the inner body panel to the outer face of the compartment to provide maximum strength. Corners using structural support channels or extrusions that require two or more pieces shall not be implemented.

The # 4 finish corner shall wrap around the side of the apparatus body and form the front compartment door jamb providing front corner protection.

REAR COMPARTMENT CORNERS - BRUSHED

The apparatus body rear compartment corners and vertical faces on both sides shall be constructed of 304 marine grade stainless steel with a # 4 annealed and polished finish. The corners shall be a one- piece fabrication from top to bottom and from the inner body panel to the outer face of the compartment to provide maximum strength. Corners using structural support channels or extrusions that require two or more pieces shall not be implemented.

Toyne Inc.

The # 4 finish corner shall wrap around the side of the apparatus body and form the rear compartment door jamb providing front corner protection.

COMPARTMENT TOPS/CEILINGS

The apparatus body compartment tops shall be constructed of 304 marine grade stainless steel with a # 4 annealed and polished finish on the interior surface.

The stainless shall be overlaid with .125" NFPA aluminum treadbrite. The aluminum treadbrite shall be an overlay only. The treadbrite shall not form any structural part of the apparatus body or shall be bottom side of the treadbrite be visible when looking into the compartment.

COMPARTMENT TOP OVERLAY

The compartment top shall be overlaid with 1/8" aluminum treadbrite. The aluminum treadbrite shall be an overlay only and shall not form any structural part of the apparatus body or shall the bottom side of the treadbrite be visible when looking into the compartment.

PAINTED FENDERWELLS

The left and right side rear fender wells shall be constructed of stainless sheet steel. The fender wells shall be radius cut and shall have a full circular inner liner to prevent rust pockets and for ease of cleaning. A 1" gap shall be provided on the bottom of each side of the circular liner to allow drainage of water and for easy cleanout. Sufficient clearance shall be provided for tire chains. Before the booster tank is installed, the fender wells shall be thoroughly cleaned and all seams sealed to prevent corrosion in the fender well area.

PAINTED FENDERWELLS

The fender wells shall be finish painted the primary exterior color of the apparatus.

UPPER DOOR POSTS - PAINTED

The upper door post to the front and rear of the compartment door above the rear wheels shall be constructed of ultra-smooth 304 marine grade stainless sheet steel with a minimum tensile strength of 90,000 psi.

The outer surface of these door posts shall be finished painted.

REMOVABLE INNER FENDER LINER

The fender wells shall be radius cut and shall have a circular inner liner to prevent corrosion pockets and for ease of cleaning. The inner liner shall be constructed of high impact polypropylene material and shall be fully removable for chassis suspension access.

To prevent the accumulation of potential corrosive materials in the fender well area, there shall be no exception to the removable inner fender liner.

STAINLESS STEEL FENDERETTE

Toyne Inc.

The fender wells shall be trimmed with a polished stainless steel fenderette. The stainless steel fenderette shall be secured into place with stainless steel fasteners and shall be easily removable for replacement. A black rubber fender welting shall be provided between the fenderette and the inner liner surface. The fenderettes shall protrude from the apparatus body a maximum of 1".

REPLACEABLE FENDERETTE

The stainless steel fenderette shall be secured to the apparatus body with stainless steel fasteners and shall be easily removable for replacement.

Fenderettes that are welded to the apparatus body are not acceptable.

OUTER BODY SIDES

The outer left and right side body panels above the compartment tops shall be constructed of 304 2B marine grade stainless steel with a # 4 brushed finish and shall not require any finish paint.

COMPARTMENT VENTILATION

Each compartment shall be ventilated to the exterior of the body through a removable metal ventilation plate in the compartment wall or through pass through ventilation into an adjoining compartment.

A cleanable filter material shall be provided behind the plate.

Plastic cover plates will not be acceptable.

ROM SERIES IV ROLL UP COMPARTMENT DOORS

For all compartments requiring roll up doors, Robinson (ROM) Series IV roll up doors shall be installed.

Each shutter slat, track, bottom rail, and drip rail shall be constructed from anodized 6063 T6 aluminum.

The shutter slats shall feature a double wall extrusion 0.315" thick with a concave interior surface to minimize loose equipment jamming the shutter door closed. Shutter slats shall feature an interlocking end shoe to prevent side to side binding of the shutter door during operation. Slats must have interlocking joints with an inverted locking flange. The slat inner seal shall be a one piece PVC extrusion designed to prevent metal to metal contact while minimizing dirt and water from entering the compartment.

The shutter door tracks shall be one piece design with integral overlapping flange to provide a clean finished look without the need of caulk. Door tracks shall feature an extruded Santoprene rubber double lip low profile side seal with a silicone co-extruded back to reduce friction during shutter operation.

The shutter bottom rail shall be a one piece double wall extrusion with integrated finger pull. The finger pull shall be curved upward with a linear striated surface to improve operator grip while operating the shutter door. The bottom rail shall have a smooth contoured interior surface to prevent loose equipment from jamming the shutter door. Bottom rail seal shall be made from Santoprene and shall be a double "V" seal to prevent water and debris from entering compartment. The bottom rail lift bar shall be a one piece "D" shaped aluminum extrusion with linear striations to improve operator grip during operation. The lift bar shall have a wall thickness of 0.125" and be supported by no less than two pivot

Toyne Inc.

blocks constructed from Type 66 Glass filled reinforced nylon for superior strength. The bottom rail end blocks shall have incorporated drain holes which will allow any moisture that collects inside the extrusion to drain out.

Shutter door shall have an enclosed counter balance system. The system shall be 4" in diameter and held in place by 2 heavy duty 18 gauge zinc plated plates. The counter balance system shall have 2 over-molded rubber guide wheels to provide a smooth transition from vertical track to counter balance system; no foam material of any kind shall be permitted or used in this area.

STAINLESS STEEL COATED FASTENERS

All fasteners used in the finish construction of the apparatus body shall be marine grade stainless steel. Fasteners that pass through a dissimilar metal panel shall be Magna-Gard, or equal, coated to help prevent metal reaction and corrosion.

As the Magna-Gard, or equal, coating is a "baked on" type coating providing for excellent adhesion to the fastener, spray on type coatings may be used in conjunction with the Magna-Gard, or equal, but not in place of it.

Because dissimilar metal corrosion is a common occurrence on all apparatus and the Magna-Gard (or similar "baked on" coatings) fasteners are commercially available to all manufacturers and is not a proprietary product, there shall be no exception to this requirement.

DRIVER'S SIDE COMPARTMENT IN FRONT OF THE REAR WHEELS

A compartment shall be provided in front of the rear wheels. The compartment interior dimensions shall be 67" high x 47.75" wide with the lower 28" of the compartment being 26" usable depth and the remaining upper section being 14" usable depth.

The compartment shall have a roll up door with a satin finish.

DRIVER'S SIDE ABOVE WHEEL COMPARTMENT

A compartment shall be provided above the rear wheels. The compartment interior dimensions shall be 37" high x 63.75" wide x 14" usable depth.

The compartment shall have roll up door with a satin finish.

DRIVER'S SIDE COMPARTMENT BEHIND REAR WHEELS

A compartment shall be provided behind the rear wheels. The compartment interior dimensions shall be 67" high x 44" wide x 26" useable depth in a portion of the lower section and the remaining upper section being 14" usable depth.

The compartment shall have a roll up door with a satin finish.

PASSENGER'S SIDE COMPARTMENT IN FRONT OF THE REAR WHEELS

A compartment shall be provided in front of the rear wheels. The compartment interior dimensions shall be 67" high x 47.75" wide with the lower 28" of the compartment being 26" usable depth and the remaining upper section being 14" usable depth.

The compartment shall have a roll up door with a satin finish.

Toyne Inc.

PASSENGER'S SIDE ABOVE WHEEL COMPARTMENT

A compartment shall be provided above the rear wheels. The compartment interior dimensions shall be 37" high x 63.75" wide x 14" usable depth.

The compartment shall have a roll up door with a satin finish.

PASSENGER'S SIDE COMPARTMENT BEHIND REAR WHEELS

A compartment shall be provided behind the rear wheels. The compartment interior dimensions shall be 67" high x 44" wide x 26" useable depth in a portion of the lower section and the remaining upper section being 14" usable depth.

The compartment shall have a roll up door with a satin finish.

REAR FACE COMPARTMENT

A rear compartment shall be provided on the apparatus just ahead of the rear step. The compartment shall be a minimum of 30" useable depth. The compartment shall have maximum height with selected apparatus options.

REAR COMPARTMENT HEIGHT

The rear facing compartment shall extend upward and shall be flush with the top of the booster tank to maximize the height of the rear compartment.

There shall not be a void area between the top of the rear facing compartment and the bottom of the hose bed nor shall the booster tank extend over the rear compartment.

REAR FACE COMPARTMENT DOOR - ROLL UP

The rear compartment shall have a roll up door. The door shall have a satin finish.

DRIVER'S SIDE REAR COMPARTMENT - TRANSVERSE

The driver's side compartment behind the rear wheels shall be open into the rear facing compartment (transverse).

PASSENGER'S SIDE REAR COMPARTMENT - TRANSVERSE

The passenger's side compartment behind the rear wheels shall open into the rear facing compartment (transverse).

REAR STEP MATERIAL - NFPA ALUMINUM TREADBRITE

The rear step shall be constructed of NFPA complaint bright finish aluminum treadbrite.

18" REAR TAILBOARD STEP

The outer rear edge of the rear step shall be positioned 18" from the rear face of the apparatus. This shall include an approximate 3/4" wash out gap at the rear face of body.

Toyne Inc.

RUBRAILS - BRIGHT ANODIZED ALUMINUM

Extruded aluminum rub rails shall be provided on the apparatus body sides. The rub rails shall have a bright finish with anodized coating to protect the finish. The rub rails shall be spaced from the apparatus body a minimum of 1/4" with poly spacers.

The rub rails must be bolted on to the apparatus body to allow easy replacement if damaged. Rub rails that are permanently fastened to the apparatus body by welding or any other permanent method will not be acceptable. **NO EXCEPTION WILL BE ALLOWED TO THIS REQUIREMENT.**

RUB RAIL ENDS

The rub rail ends shall be 'capped' with a high impact resistant black EPDM contoured block.

HOSE BED FLOORING

The floor of the hose bed shall be constructed of fiber reinforced Dura-Dek, or equal, material.

The top portion of each "T" cross section shall measure 1 5/8" wide x 3/16" thick with beaded ends. The vertical portion shall be 3/16" thick tapering out at the bottom to a thickness of 1/2" and have an overall height of 1". The "T" sections shall be spaced 3/4" apart to allow for drainage and ventilation.

The flooring shall then be protected with a polyurethane coating to screen out ultraviolet rays. The gray colored coating shall be baked on and include a slip resistant material.

HOSE BED CAPACITY

The hose bed shall provide 60 cubic feet of hose storage.

The above listed capacity may be effected by other equipment mounted in hosebed.

HOSE BED DIVIDER(S)

There shall be one (1) hose bed divider(s) to partition off hose. The divider(s) shall be constructed of 3/16" thick aluminum plate material. The lower edge of the divider(s) shall have a two inch 90-degree bend toward one side and a 2" x 2" x 3/16" aluminum angle welded to the other side.

The divider(s) shall be adjustable by sliding in tracks which are recessed flush into the hose bed flooring, one on front and one on rear. The divider shall be held in place by two bolts on each end.

The upper rear corner of the divider(s) shall have a minimum of a 3" radius cut with a 1" aluminum rub plate.

HOSE BED BULKHEAD

A bulkhead divider shall be provided in the front area of the hose bed separating the hose bed from the tank fill tower(s).

Toyne Inc.

HOSE BED COVER WITH VELCRO FASTENERS

A heavy duty vinyl coated nylon hose bed cover shall be provided to protect the hose load from the weather. The cover shall extend from the front of the hose bed to the rear and then extend downward to cover the exposed rear of the bed.

The cover shall have a double reinforced area where the cover comes into contact with the upper rear corners of the hose bed dividers. The cover shall be secured to the apparatus using Velcro on the sides and lift dots on front.

The rear of the cover shall be secured to the apparatus using positive mechanical latches.

HOSE BED COVER - RED

The hose bed cover shall be red.

LOW MOUNT ENCLOSED LADDER COMPARTMENT

A ladder storage compartment shall be provided on the right side of the apparatus with an access door on the rear. The compartment shall be located below the hose bed level and shall not be located above or through the booster tank. The compartment shall be located between the booster tank and the right side compartments.

For ease of removal and replacement, the compartment shall be designed to carry all portable ladders vertically on their beams. Ladder racks that carry the ladders horizontally shall not be acceptable.

The compartment shall be constructed of 5052 1/8" aluminum. Individual slides shall be provided in the compartment on both sides to allow individual storage for all ladders. The slides shall be provided with permanently attached Rodex poly slip blocks with tapered front and rear edges allow easier loading/unloading of the ladders.

All ladders shall be capable of being removed individually without disturbing the remaining ladders.

LADDER COMPARTMENT DOOR

A smooth aluminum vertically hinged door with a slam-type latch shall be provided on the compartment. The latch shall be activated by a large "D" ring control. The use of lift-and-turn or small snap type latches on this door shall not be acceptable.

The door shall be covered with Chevron material.

PIKE POLE STORAGE

Storage for two straight handle pike poles shall be provided in the ladder storage compartment.

LADDER COMPARTMENT LIGHT

An LED light shall be provided in the ladder storage compartment. The light shall be mounted just inside the ladder compartment access door and activated with an automatic door switch.

The light switch shall be incorporated into the door ajar warning system in the cab.

Toyne Inc.

DUO SAFETY 24' 2-SECTION ALUMINUM LADDER

One (1) Duo Safety 900A 24' NFPA compliant two section aluminum extension ladder provided and mounted.

DUO SAFETY 14' ALUMINUM ROOF LADDER

One (1) Duo Safety model 775A 14' NFPA compliant aluminum roof ladder with folding hooks shall be provided and mounted.

DUO SAFETY 10' ALUMINUM FOLDING ATTIC LADDER

One (1) Duo Safety 585A 10' NFPA compliant aluminum folding attic ladder shall be provided and mounted.

LOW MOUNT ENCLOSED HARD SUCTION

Storage for hard suction shall be provided on the left side of the apparatus with an access door on the rear. The compartment shall be located below the hose bed level and shall not be located above the booster tank. The compartment shall be located between the booster tank and the left side compartments.

The compartment shall be constructed of 5052 1/8" aluminum. Individual slides constructed of PVC shall be provided for storage of two lengths of hard suction.

All hard suction shall be capable of being removed individually without having to disturb the remaining hard suction.

The compartment shall have a small LED light mounted just inside the door with an automatic door switch. The light shall be incorporated into the door ajar warning system in the cab.

HARD SUCTION COMPARTMENT DOOR

A smooth aluminum vertically hinged door with a slam-type latch shall be provided on the compartment. The latch shall be activated by a large "D" ring control. The use of lift-and-turn or small snap type latches on this door shall not be acceptable.

The door shall be covered with Chevron material.

6" x 10' HARD SUCTION HOSES (2)

Two sections of 6" diameter x 10' length clear lightweight PVC hard suction hose shall be provided.

The hard suction shall be coupled long handle female NST x rocker lug male NST.

The hard suction shall be Kocheck brand.

Toyne Inc.

COMPARTMENT SHELF TRACKS - ALUMINUM

Four (4) sets consisting of two heavy duty aluminum adjustable tracks shall be provided in specified compartments, one for each end of shelf.

The tracks shall not be welded to the apparatus body.

SHALLOW DEPTH COMPARTMENT SHELVING

There shall be four (4) shallow depth shelves provided. The shelves shall be constructed of 1/8" smooth aluminum with a 2" upward bend on the front and rear edges.

1 in each tall compartment

The shelves shall have a random orbit sanded finish.

TURTLE TILE SHELF MAT

Each shallow depth shelf shall have Turtle Tile matting.

COMPARTMENT SCBA TRACKS - HORIZONTAL

Two (2) sets consisting of two heavy duty horizontally mounted adjustable tracks shall be provided and mounted to the rear walls of the specified compartment(s).

The tracks shall not be welded to the apparatus body.

D2 and P2

SCBA SEAT BRACKET(S)

There shall be four (4) Superior Flamefighter SCBA bracket(s) provided. The cylinder clips shall be spring steel for greater durability and long life.

A model 39015-12 NFPA 1901 approved restraint strap shall be provided for each bracket.

WHEELWELL SPARE CYLINDER COMPARTMENTS - 8 CYLINDERS TOTAL

Four individual spare SCBA cylinder compartments shall be provided, located two (2) on each side of the apparatus, one forward of the rear axle and one behind the rear axle.

The compartments shall be a one piece injection molded high strength polyethylene designed specifically for the SCBA cylinder storage. The compartments shall be slanted towards the rear.

Each compartment shall hold two cylinders for a total storage capacity of 8 cylinders.

Toyne Inc.

WHEELWELL SPARE CYLINDER COMPARTMENT DOORS - BRUSHED STAINLESS

Brushed finish stainless steel access doors shall be provided on each spare cylinder compartment in the wheelwell.

WHEELWELL SCBA CYLINDER COMPARTMENT RETENTION STRAPS

One 1" wide loop of high visibility yellow webbing shall be installed in each wheel well spare cylinder compartment for each cylinder to be stored in the compartment. The loop(s) shall be designed to loop around the cylinder valve and help prevent the cylinder from sliding out of the compartment if the door is not latched or fails.

TURTLE TILE FLOOR MATS

All lower level apparatus body compartment floors shall be provided with 3/4" thick Turtle Tile modular 12" x 12" square tiles with perforated surface for ventilation and air circulation. The tiles shall be easily removable for cleaning the compartment. The tiles shall interlock into each other to form a "one piece" floor liner.

Floors with permanent mounted or bolted in place accessories will not have floor mats.

TURTLE TILE - BLACK

The Turtle Tile shall be black in color.

FOLDING ACCESS STEPS

Southpark model LFS46ZC chrome plated folding access steps shall be provided in areas listed in these specifications. All access steps provided on the apparatus shall support a minimum static load of 500 lbs. and be mounted in accordance to recommended mounting procedures as outlined by NFPA 1901. The steps shall be **minimum** of 6.5" wide x 6.5" depth. The steps shall be attached to the apparatus using stainless steel bolts with locking type nuts.

Four NFPA compliant folding steps shall be provided on the rear of the apparatus on the left side.

NFPA KNURLED FINISH HANDRAILS

All handrails shall be 1 1/4" diameter extruded aluminum "knurled finish" with chrome plated stanchions. Rubber gaskets shall be provided between the stanchions and any painted surfaces.

LEFT REAR VERTICAL HAND RAILS

An NFPA compliant handrail shall be provided on the left rear of the apparatus for boarding the rear step and using the left rear hose bed access steps.

RIGHT REAR VERTICAL HAND RAILS

An NFPA compliant handrail shall be provided on the right rear of the apparatus for boarding the rear step and using the right rear hose bed access steps.

Toyne Inc.

LEFT REAR GRAB RAIL

A 12" NFPA compliant horizontal handrail shall be provided on the left rear of the apparatus towards the rear of the hose bed.

INTERMEDIATE REAR HORIZONTAL HAND RAIL

An intermediate horizontal handrail shall be provided on the rear of the apparatus.

WALKWAY GRAB RAILS

1 1/4" diameter extruded aluminum "knurled finish" handrails with chrome plated stanchions shall be provided on each side of the walkway entry.

NFPA 1901 CERTIFIED 12 VOLT ELECTRICAL SYSTEM

The 12-volt apparatus body electrical system shall be provided and shall be in compliance with NFPA 1901 testing and certification procedures as follows:

NFPA MINIMUM ELECTRICAL LOAD DEFINITION

The NFPA 1901 defined minimum electrical load shall consist of the total amperage required to simultaneously operate the following in a stationary mode:

- Propulsion engine and transmission.
- The clearance and marker lights.
- Communication equipment (5 amp default).
- Illumination of all walking surfaces, the ground at all egress points, control and instrumentation panels and 50% of total compartment lighting.
- Minimum warning lights required for "blocking right of way" mode.
- The current to simultaneously operate and fire pump and all specified electrical devices.
- Anything defined by the purchaser, in the advertised specifications, to be critical to the mission of the apparatus.

RESERVE CAPACITY TEST

A Reserve Capacity Test shall be performed on the completed apparatus. All items listed in NFPA Minimum Load Definition shall be activated with the engine shut off. After 10 minutes of operation, those items shall be deactivated. After deactivation, the battery system shall have ample reserve to start the engine.

ALTERNATOR PERFORMANCE TEST AT IDLE

An "alternator performance test at idle" test shall be completed. The minimum continuous electrical load shall be activated with the engine running at idle speed. When the engine temperature has been stabilized at idle speed, the battery system shall be tested to detect any battery discharge current.

ALTERNATOR PERFORMANCE TEST AT FULL LOAD

Toyne Inc.

An "alternator performance test at full load" test shall be completed. The minimum continuous electrical load shall be activated with the engine running up to the engine manufacturer's governed speed for a 2 hour period.

TEST CONDITIONS

All electrical testing shall be performed with the engine compartment at approximately 200 degrees.

12-VOLT WIRING SYSTEM

All 12-volt electrical wiring shall be SXL cross link rated to carry 125% of the maximum current for which the circuit is protected. The wire shall be of sufficient size so that voltage drop in any electrical device does not exceed 10%. All wiring shall be color, number, and function coded with the number and function being printed every 3" along the entire length of all apparatus body wires (as required by NFPA 1901). All wiring shall be routed through heavy duty PVC split loom securely attached and protected against heat, oil, and physical damage. All locations where the wire passes through a body panel shall be protected with electrical grommets.

All connections shall be made using mechanical connectors and be screwed to terminal or junction box with machine screws. Wire nut, insulation displacement, or piercing connections shall not be used.

All circuits shall be provided with properly rated low voltage over current protective devices of the automatic reset type.

Removable access panels shall be provided to provide access to the wire and electrical components.

REAR LICENSE PLATE LIGHT/BRACKET

A chrome plated LED license plate light shall be provided on the rear of the apparatus.

A license plate mounting bracket shall be provided that spaces the license plate away from the apparatus body.

CLEARANCE LIGHTS/REFLECTORS

All apparatus body clearance lights shall be LED style. All lower clearance lights and reflectors shall be mounted in a manner that provides protection from damage, and shall comply with FMVSS-108 regulations.

MID-MOUNTED SIDE TURN SIGNAL - LED

An amber LED side turn signal shall be provided in the mid-section area of the apparatus on both sides.

LED PUMP COMPARTMENT LIGHTS (2)

Two LED compartment lights shall be provided to illuminate the pump compartment. The lights shall function with the pump operators gauge panel lights.

DUAL TRACK TYPE LED COMPARTMENT LIGHTING

Each apparatus body compartment shall have two track type LED lights vertically mounted in the compartment. The lights

Toyne Inc.

shall be constructed of an unbreakable type clear poly type flexible material housed in an aluminum extrusion.

A compartment that is considered a 'full height' compartment shall each have two 48" long light sections and a 'low height' or above wheel compartment shall each have two 18" long sections.

The lights shall function automatically and independently of other compartments when the compartment door is opened. **Compartment lighting systems that are controlled by a single, dash mounted switch are not acceptable.**

COMPARTMENT LIGHT SWITCHES

Each hinged apparatus body door compartment shall have a magnetic style reed indicator switch.

Each roll up door shall have an integral door open indicator magnet in the lift bar. If the bar is not properly closed, it shall activate the "Door Open" light in the cab.

The compartment lights shall function automatically when the door is opened. A master compartment light switch shall not be acceptable.

DOOR AJAR INDICATOR - LED

A red LED flashing light shall be provided on the switch console area to warn of an open compartment or personnel door.

A label shall be provided that states "Do Not Move Apparatus When Light Is On".

AUDIBLE DOOR AJAR INDICATOR

In addition to the flashing door ajar indicator, an audible alarm shall be provided in the cab to warn of an open compartment or personnel door.

DOOR AJAR INDICATOR PARK BRAKE DISABLE

All apparatus body door ajar indicators shall be disabled when the park brake is set.

PERIMETER GROUND LIGHTING five (5)

There shall be five (5) 4" diameter underbody LED perimeter lights furnished and installed. The lights shall have an unbreakable polycarbonate lens and housing. The lights shall be sealed to help prevent moisture entry.

The ground lights shall be activated with the parking brake.

LED APPARATUS BODY STEP LIGHTING

All apparatus steps and running boards shall be illuminated using chrome plated or stainless steel LED lights. The lights shall function automatically with the park brake.

GROUND/STEP LIGHTING CUTOFF SWITCH

Toyne Inc.

A ground/step light cut off switch shall be provided in the cab to allow the driver to disable the ground lights and other lights that activate when the parking brake is set. The switch shall automatically re-set itself when the parking brake is released.

KUSSMAUL LPC40 BATTERY CHARGER

A Kussmaul LPC40 fully automatic battery charger with 40 amp output shall be installed on the apparatus. Remote voltage sensing shall be provided to compensate the charger output for the voltage drop in the charging wires.

A 15 amp DC auxiliary output circuit shall be provided on the charger.

KUSSMAUL AUTO-PUMP AIR COMPRESSOR

A Kussmaul Auto-Pump 120-volt air compressor shall be provided on the apparatus. The compressor shall have a .76 cfm open flow with a maximum pressure of 100 psi. The pressure switch shall be pre-set at 70 psi cut in and 90 psi cut out.

AUTO-EJECT SHORELINE CONNECTION

A Kussmaul 20 amp 120-volt Super Auto-Eject shall be provided. The unit shall automatically eject the connecting plug when the engine is cranked.

The connection shall be located under the driver's door.

AUTO-EJECT COVER - YELLOW

The Auto-Eject shall have a spring loaded cover yellow in color.

AUTO-EJECT MATING PLUG

A NEMA 5-20P mating female cord end shall be shipped loose with the apparatus to allow the Fire Department to connect the cord end to a Fire Department provided charging cord.

WHELEN C6 TRI-CLUSTER TAILLIGHTS - LED

Whelen C6BTT LED taillights, C6T LED turn signals and a C6BU clear LEC backup lights shall be provided.

A PLASC3V chrome plated trim housing shall be provided, one each side for mounting the tail lights, turn signal lights, and backup lights.

BACKUP LIGHTS PARK FUNCTION

The backup lights shall automatically activate when the park brake is set to provide work lighting at the rear of the apparatus.

Toyne Inc.

BACKUP ALARM

One (1) 97db backup alarm(s) shall be provided and shall automatically activate when the apparatus transmission is placed into reverse.

The backup alarm(s) shall exceed all NFPA1901 and SAE J994 Type D requirements and testing.

CONSOLE MOUNTED CONTROL PANEL

A control console shall be provided between the driver's and officer's seats for all warning/auxiliary light controls and pump shift.

WARNING LIGHT SWITCH - SINGLE

A single master optical warning device switch shall be provided that will activate all minimum optical warning lighting through a single switch. Individual switches shall not be provided for any minimum optical warning lighting to insure total compliance to the warning lighting requirements defined in NFPA 1901. All lighting controlled by this switch shall not be subject to load management.

Any warning lights that are installed on the apparatus that are not required to meet the minimum optical warning lighting requirements shall be subjected to load management and shall have individual switches to activate/de-activate the warning light.

All switches shall be clearly labeled as to their function.

CENTER CONSOLE MAP POCKET

A 16" long (side to side) x 2 3/4" wide (front to rear) and 8" depth storage pocket shall be provided on the rear of the console for storing books, maps, etc. The pocket shall be constructed of aluminum treadbrite.

CENTER CONSOLE CONSTRUCTION MATERIAL

The console shall be constructed of aluminum treadbrite.

CENTER CONSOLE PANEL MATERIAL

The console panel shall be constructed of brushed stainless steel.

Whelen warning light pkg HGRP-P (commercial)

ZONE A UPPER WARNING LIGHTING

A Whelen Justice JE2NFPA LED lightbar shall be mounted on the top of the cab roof. The lightbar shall be 56" in length and mounted with low profile stainless steel brackets. The lightbar shall have four corner red linear LED's and six CON3 front LED's (4 red/2 white).

Toyne Inc.

ZONE C UPPER WARNING LIGHTING

Two Whelen model L31HRFN NFPA LED red beacons shall be provided one on each side on the rear.

WHELEN C6LR SUPER MAX LED LOWER ZONE A WARNING LIGHTING

Two Whelen C6LR Super Max red LED light heads shall be mounted in the grille area on the apparatus.

C6FC chrome trim housings shall be provided.

WHELEN C6LR SUPER MAX LED INTERSECTION WARNING LIGHTING

One Whelen C6LR Super Max red LED light head shall be mounted on each side in a low forward position. A C6FC chrome bezel shall be provided around the lights.

INTERSECTION WARNING LIGHT - SIDES

One Whelen ION Mini T TLMIR red LED light shall be provided on each side as low and far forward as possible on the apparatus.

TIONMFC chrome trim housings shall be provided.

MID-SECTION WARNING LIGHTS - SIDES

One Whelen TLMIR ION Mini T red LED light shall be provided on each side in the mid-section of the apparatus.

TIONMFC chrome trim housings shall be provided.

SIDE FACING LOWER REAR WARNING LIGHTS

One Whelen TLM1R ION Mini T red LED light shall be provided shall be provided on each side of the apparatus as low and as far rearward as possible on the apparatus.

TIONMFC chrome trim housings shall be provided.

Toyne Inc.

WHELEN C6LR SUPER MAX LED LOWER REAR WARNING LIGHTS

Two Whelen C6LR Super Max red LED light heads shall be mounted on the rear of the apparatus in a low position. A C6FC chrome bezel shall be provided around the lights.

WHELEN 295SLSSA1 SIREN

A Whelen 295SLSA1 siren shall be provided and mounted in the cab.

Siren certifications, etc.

100 WATT SPEAKER

A 100 watt speaker shall be provided and recessed into the front bumper. The model of speaker installed shall be designed to fit bumper type.

FRC SPA900-Q70 SCENE LIGHTS (4)

Four FRC SPA900-Q70 scene lights shall be provided and mounted one on each side and two on the rear. The lights shall be 12VDC and create up to 7,000 lumens each.

Chrome trim housings shall be provided.

12 VOLT SCENE LIGHT ACTIVATION SWITCHES (3)

Three switches shall be provided to activate the 12 volt scene light(s). The driver's side lights, passenger's side lights and the rear lights shall each be individually switched. The switches shall be located on the cab control console.

DUAL FUNCTION SCENE LIGHT(S)

The side rear and rear facing scene light(s) shall activate automatically when the apparatus transmission is placed into reverse.

LED HOSE BED LIGHT

One LED light shall be provided and mounted in the front of the hose bed .

The light shall be controlled by the pump panel light switch.

FRC SPECTRA LED TELESCOPING LIGHT - 12 VOLT

Two Fire Research model SPA540-Q15 top raising telescoping light(s) shall be mounted on the apparatus. The lighthouse

Toyne Inc.

shall be 12 volt LED and shall draw a maximum of 13.9 amps creating 15,000 lumens.

The telescoping pole shall be constructed of heavy wall anodized tube. The pole shall be secured in any raised position with a non-directional advanced twist lock locking device. The twist lock mechanism shall have a knurled positive grip.

The light(s) shall be electrically tested so that they are safe for their intended use. The light(s) shall be certified by Underwriters Laboratories (UL) and shall meet/exceed NFPA 1901.

The telescoping light(s) shall be equipped with a FRC "ON" switch on the lighthouse(s).

The telescoping light(s) shall be equipped with a FRC "TW" retractile coil cord out of the lighthouse.

The telescoping light(s) shall be mounted at the pump panel.

FIRE HELMET MOUNTING

The end user of the apparatus shall be responsible for insuring that all helmets are either stored in an exterior compartment or a securely mounted to NFPA 1901 standards inside the cab.

PAINT PROCEDURE - PPG DELFLEET BASE COAT/CLEAR COAT

All interior compartment surfaces shall remain # brushed stainless steel. There shall be no paint or any other type of coating on the interior compartment surfaces. Standard mill finish, DA finish or swirled finish shall not be accepted.

Any exterior surfaces that are to be painted shall be individually listed in the apparatus body portion of this specification.

All seams or flanges on the apparatus body shall be caulked or properly sealed to prevent moisture accumulation in flanged areas.

PPG CERTIFIED 10 YEAR LIMITED PAINT WARRANTY

The apparatus body exterior finish paint shall have a 10 year limited warranty. The warranty shall be certified by the manufacturer of the paint. Documentation of this shall be provided to the end user. Any warranty that is extended by the apparatus manufacturer and not backed by the paint manufacturer will not be acceptable.

PPG Commercial OEM Product Warranty Coverage:

Warranty Inclusions:

- Delamination of the topcoat and/or other layers of paint.
- Cracking or checking due to failure of the product.
- Excessive loss of gloss caused by cracking, checking and hazing.

Warranty Exclusions:

Toyne Inc.

- Paint deterioration caused by blisters, bubbles, flaking or other degradation due to rust or corrosion originating from the substrate.
- Hazing, chalking or loss of gloss caused by improper care, abrasive polishes, cleaning agents, heavy-duty pressure washing, or aggressive mechanical wash systems.
- Paint deterioration caused by abuse, scratches, chips, gloss reduction, accidents, acid rain, chemical fallout, road treatment materials/chemicals or acts of nature.
- Any paint that was not applied by Toyne, Inc.
- Claims presented without proper Warranty documentation.
- Failure on finishes performed by Non-PPG Commercial Certified Technicians.
- Failure on finishes due to inadequate film builds.
- Failures due to improper cleaning or surface preparation or failure to follow the product use instructions.

THESE ARE THE ONLY WARRANTIES THAT PPG MAKES, AND ALL OTHER EXPRESSED OR IMPLIED WARRANTIES, INCLUDING WITHOUT LIMITATIONS, ANY WARRANTY OF FITNESS FOR PARTICULAR PURPOSE OR USE, ARE DISCLAIMED BY PPG.

ELECTROLYSIS CORROSION CONTROL

The apparatus shall be assembled using ECK or electrolysis corrosion control, on all high corrosion potential areas, such as door latches, door hinges, trim plates, fenderettes, etc. This coating is a high zinc compound that shall act as a sacrificial barrier to help minimize electrolysis and corrosion between dissimilar metals. This shall be in addition to any other barrier material that may be used.

SINGLE COLOR APPARATUS BODY PAINT

The apparatus body shall have a single color non-metallic paint scheme.

APPARATUS BODY UNDERCOATING

The apparatus body shall be undercoated after assembly is completed. A bituminous based automotive type undercoat shall be used. Care shall be taken to avoid undercoat application to items that would hinder normal maintenance.

COMPARTMENT INTERIORS - BRUSHED STAINLESS FINISH

The compartment interiors shall be brushed stainless steel # 4 finish. The brushed finish shall be as provided by the manufacturer of the material.

Interiors with any type of paint, sprayed-on coatings, DA finish, or standard "mill finish" will not be acceptable.

TIRE PRESSURE VISUAL INDICATOR - SINGLE AXLE

Real Wheels RWTG1234 valve stem mounted visual indicators shall be provided on each tire. The LED indicators shall flash when the tire pressure drops 8 psi.

LETTERING

Toyne Inc.

The Fire Department shall provide and install all vehicle lettering and numbering.

6" NFPA REFLECTIVE STRIPE

A 6" reflective stripe shall be applied to the apparatus. The stripe shall be applied to a minimum of 50% of the length of the apparatus on each side and 25% across the front of the apparatus. The stripe shall comply with NFPA 1901 requirements.

PRIMARY REFLECTIVE STRIPE COLOR - WHITE

The primary reflective stripe shall be 680-10 white.

REFLECTIVE STRIPE - HORIZONTAL

The reflective stripe shall be applied in a straight horizontal line from front to rear. The height of the stripe on the chassis cab and the body shall be as close as possible.

INNER CAB DOOR REFLECTIVE STRIPING - 4 DOOR

A minimum of 100 square inches of reflective material shall be provided on the inner door liner of each cab door.

REAR CHEVRON STRIPING

A minimum of 50 percent of the rear vertical surface of the apparatus shall be covered with 6 inch alternating red and fluorescent yellow green retro-reflective striping. The striping shall slope downward away from the centerline of the apparatus at a 45-degree angle.

The retro-reflective material shall conform to the requirements of ASTM D 4956 "Standard Specification for Retro-Reflective Sheeting for Traffic Control", Type I or better.

ENGINE HORIZONTAL EXHAUST

Shielding shall be provided between the apparatus body and the exhaust pipe if necessary to deflect heat away from the body. The exhaust system shall be designed and installed to comply with EPA equipment requirements and shall not be modified.

CAB ENTRY STEP COVER

The OEM provided cab entry step on the side opposite the fuel tank shall be removed from the chassis provided brackets and replaced with a fabricated aluminum treadbrite step assembly.

FUEL TANK/STEP COVER

The OEM provided cab entry step on the same side as the fuel tank shall be removed from the chassis provided brackets and replaced with a fabricated aluminum treadbrite step assembly.

Toyne Inc.

REAR MUD FLAPS

Heavy duty black rubber mud flaps shall be provided on the rear wheels. The mud flaps shall be attached to the apparatus in the rear wheel well area using heavy duty stainless steel retention straps that are secured into place using stainless steel fasteners.

FRONT/REAR AXLE NUT COVERS AND BABY MOONS

The front and rear axles shall have stainless steel nut covers and baby moons.

REAR PULLING EYES

Two rear 3/4" CRS pulling eyes shall be provided under the rear tailboard. The eyes shall have a minimum of a 3" clear opening for passing chains through the eye.

BATTERY DANGERS LABEL - FAMA01

A permanent label shall be provided near the battery location that warns of potential injury or death that could be caused by the batteries. The label shall also state precautions that should be taken while working on or around the batteries.

ROTATING SHAFTS DANGER LABEL - FAMA02

A permanent label shall be provided on each side of the frame rail and in any other location(s) where rotating shaft hazards are apparent. The label shall warn of potential injury or death that could be caused by the movement of the shaft(s) as well as precautions that should be taken while working on or around them.

HOT SURFACE DANGERS LABEL - FAMA03

A permanent label shall be provided near any hot surface that warns of potential injury or death that could be caused by contact with the surface. The label shall also state precautions that should be taken while working on or around the surface.

HOT EXHAUST DANGERS LABEL - FAMA04

A permanent label shall be provided near any hot exhaust surface that warns of potential injury or death that could be caused by contact with the surface. The label shall also state precautions that should be taken while working on or around the surface.

SPINNING ENGINE FAN DANGER LABEL - FAMA05

A permanent label shall be provided on both sides of the engine fan. The label shall warn of potential injury or death that could be caused by the movement of the fan as well as precautions that should be taken while working on or around them.

SEATED AND BELTED WARNING LABEL - FAMA07

A permanent label shall be provided that is visible to all occupants that states that they should be seated and belted while

Toyne Inc.

the apparatus is in motion. The label shall also state potential injuries or death that could be caused if the safety belts are not used properly.

AIR CONDITIONING REFRIGERANT WARNING LABEL - FAMA09

If the apparatus is equipped with any type of air conditioning system, a permanent label shall be provided that is located in an area that would be visible to service personnel. The label shall state that the system contains R134A, the necessary precautions that should be taken and the dangers of working on or around the system.

CAB INTERIOR EQUIPMENT MOUNTING DANGER LABEL - FAMA10

A permanent label shall be provided inside of the cab warning of the dangers of unsecured equipment inside the cab. The label shall state that all equipment shall be properly secured and also warn of potential injury or death that could be caused by failing to do so.

SCBA SEAT DANGER LABEL - FAMA11

If the apparatus is equipped with SCBA seats in the cab, a permanent label shall be provided inside of the cab warning of the dangers of using the seat without the SCBA properly secured or seat insert in place. The label shall warn of potential injury or death that could be caused by improper use of the seat.

FIRE SERVICE TIRE RATING LABEL - FAMA12

A permanent label shall be provided inside of the cab in view of the driver while entering the cab warning of the dangers of improper use of the tires on the apparatus. The label shall also warn of potential injury or death that could be caused by improper tire use or condition.

ELECTRONIC STABILITY CONTROL LABEL - FAMA13

If the apparatus is equipped with an electronic stability control system, a permanent label shall be provided inside of the cab in view of the driver warning of the dangers of improper operation of the apparatus and the importance of safe driving. The label shall also warn of potential injury or death that could be caused by improper operation of the apparatus.

MAXIMUM OCCUPANCY LABEL - FAMA14

A permanent label shall be provided inside of the cab in view of the driver stating the maximum number of personnel that can ride in the apparatus. The label shall also warn of potential injury or death that could be caused by exceeding the stated capacity.

DO NOT WEAR HELMET LABEL - FAMA15

A permanent label shall be provided inside of the cab in view of all seated positions stating that helmets should not be worn in cab. The label shall also warn of potential injury or death that could be caused by wearing helmet in cab.

VEHICLE BACKING LABEL - FAMA17

Toyne Inc.

A permanent label shall be provided inside of the cab in view of the driver advising of proper procedures to following when the apparatus is in reverse motion. The label shall also warn of potential injury or death that be caused by failing to follow proper procedures.

INTAKE/DISCHARGE CAP PRESSURE LABEL - FAMA18

A permanent label shall be provided in all areas that intakes and discharges are capped. The label shall give instruction on how to properly remove the cap. The label shall also warn of potential dangers, injury or death that be caused by failing to follow proper cap removal procedures.

HOSE RESTRAINT LABEL - FAMA22

A permanent label shall be provided near any hose storage area. The label shall instruct the operator to insure that all hose is properly secured prior to placing the apparatus in motion and to provide warning of potential dangers, including injury or death, in failing to do so.

ACCESS STEPS/LADDER LABEL - FAMA23

A permanent label shall be provided at any area of the apparatus where personnel will be boarding or exiting the apparatus. The label shall instruct the operator in the proper method of climbing into or onto the apparatus as well as exiting and provide indication of potential injury or death that could occur in failing to do so.

DO NOT RIDE ON REAR STEP WARNING LABEL - FAMA24

A permanent label shall be provided at the rear step area stating that riding in this area while the vehicle is in motion is prohibited and shall warn of the potential dangers, including injury or death, in doing so.

DO NOT RIDE IN WALKWAY WARNING LABEL - FAMA24

A permanent label shall be provided in the walkway/crosswalk stating that riding in this area while the vehicle is in motion is prohibited and shall warn of the potential dangers, including injury or death, in doing so.

DO NOT RIDE IN WALKWAY WARNING LABEL - FAMA24

A permanent label shall be provided in the walkway/crosswalk stating that riding in this area while the vehicle is in motion is prohibited and shall warn of the potential dangers, including injury or death, in doing so.

TRAINED OPERATOR ONLY LABEL - FAMA25

A permanent label shall be provided on the pump panel that states that only properly trained personnel should operate the apparatus and shall indicate that injury or death could occur as a result.

NOT A STEP WARNING LABEL - FAMA26

A permanent label shall be provided in any horizontal location that a firefighter may feel tempted to use as a step but is not designed, constructed or intended to be a stepping, standing or walking surface. The label shall state that the surface is not intended for this purpose and indicate potential injury or death in doing so.

Toyne Inc.

COMPARTMENT TOP WARNING LABEL - FAMA26

A permanent label shall be provided on the front and rear of the compartment tops on both sides warning that the area is not designed, constructed or intended to be a stepping, standing or walking surface. The label shall state that the surface is not intended for this purpose and indicate potential injury or death in doing so.

SIREN NOISE WARNING LABEL - FAMA42

A permanent label shall be provided inside the driver's door warning of potential injury that could be received from the noise of the siren. The label shall also state safety precautions that should be taken when the siren is in use.

TANK FILL RATE LABEL

A permanent label shall be provided near any tank fill location clearly stating the following tank fill limitations and procedures:

- Do not exceed 100 psi when filling tank.
- Fill rate in GPM = tank size capacity.
- For tanks over 1000 gallons, do not exceed maximum fill rate of 1,000 GPM.
- Gate back fill when water reaches top of the tank.

The label shall also state that failure to follow procedure could result in over-pressurization, premature tank failure and possibly void tank warranty.

FLUID CAPACITY LABEL

A permanent plate shall be mounted in the driver's compartment specifying the quantity and type of the following fluids used in the apparatus (if applicable) for normal maintenance:

- Engine oil.
- Engine coolant.
- Chassis transmission fluid.
- Pump transmission fluid.
- Pump primer fluid.
- Drive axle fluid.
- Air conditioning refrigerant.
- Air conditioning lubrication oil.
- Power steering fluid.
- Cab-tilt mechanism fluid (if applicable).
- Transfer case fluid (if applicable).
- Equipment rack fluid (if applicable).
- CAFS compressor system lubricant (if applicable).
- Generator system lubricant (if applicable).
- Front tire cold pressure.
- Rear tire cold pressure.
- Maximum tire speed ratings.

LENGTH, HEIGHT, WEIGHT LABEL

Toyne Inc.

A permanent plate or label shall be provided in the cab stating the overall length, height and the gross vehicle weight rating (GVWR), in tons, of the completed apparatus.

The wording on this label shall indicate that the information on the plate/label was current at the time of manufacture and if the overall height of the apparatus changes while the vehicle is in service, the purchaser shall revise the height dimension on the plate.

OPTICAL WARNING LIGHT CERTIFICATION

The emergency warning light system shall be certified using one of the available methods provided for in NFPA 1901 13.8.16.

SIREN CERTIFICATION

The siren manufacturer shall certify the siren to NFPA 1901 13.9.1.1.

ELECTRICAL SYSTEM PERFORMANCE CERTIFICATION

A written load analysis and the results of the electrical system performance test shall be provided with the completed apparatus. The load analysis shall include the following:

- Nameplate rating of the alternator.
- The alternator rating under the conditions specified in NFPA 1901 13.3.2.
- Each of the component loads specified in NFPA 1901 13.3.3 that make up the minimum continuous electrical load.
- Additional electrical loads that, when added to the minimum continuous electrical load, determine the total continuous electrical load.
- Each individual intermittent electrical load.

BOOSTER TANK CAPACITY CERTIFICATION

The manufacturer shall certify the capacity of the booster tank. Certification shall be documented on the Manufacturer's Record of Construction document.

CLASS A FOAM TANK CERTIFICATION

Certification of class A foam tank capacity shall be provided.

NFPA SLIP RESISTANCE CERTIFICATION

Any materials used as a stepping, standing or walking surface shall be certified to be compliant with NFPA 1901 15.7.4. Documentation shall be provided with the completed apparatus.

WEIGHT CERTIFICATION

Documents from a certified scale showing actual loading on the front, rear and overall apparatus shall be provided. The apparatus shall be scaled with the water tank full but without personnel, equipment and hose.

Toyne Inc.

VEHICLE ROLLOVER STABILITY

The apparatus chassis shall be equipped with a stability control system and shall be certified to NFPA 1901 Rollover Stability requirements.

UNDERWRITER'S LABORATORIES TESTING

The apparatus shall undergo an Underwriter's Laboratories Certification Test to insure that the completed apparatus meets the requirements of NFPA 1901. The certificate shall be provided to the purchaser upon completion. Underwriter's Laboratories shall also perform the required testing on the entire installed electrical system. Self-certification by the apparatus manufacturer will not be acceptable.

MANUFACTURER'S RECORD OF APPARATUS CONSTRUCTION

All information required to comply with NFPA 1901 4.20.1 shall be provided with the completed apparatus.

OPERATIONS AND SERVICE DOCUMENTATION

The apparatus shall be complete with all operation and service documentation covering the apparatus as delivered and accepted. The documentation shall address the inspection, service and operations of the apparatus and all major components as required in NFPA 1901 4.20.2.

"AS BUILT" APPARATUS BODY OWNERS MANUALS (2)

Two "as built" apparatus body owner's manual USB drives shall be provided with the apparatus. All apparatus body electrical schematics shall be provided as well as all instructional and maintenance manuals on components provided and permanently mounted on the apparatus. A copy of the final apparatus body build specifications shall also be included on the drive. The USB shall be "read only" and shall not allow modification.

To eliminate component confusion, generic documentation with equipment that is not provided on the apparatus body shall not be acceptable.

FAMA FIRE APPARATUS SAFETY GUIDE

One (1) FAMA Fire Apparatus Safety Guide(s) shall be provided with the completed apparatus.

STATEMENT OF EXCEPTION - NFPA MISCELLANEOUS REQUIRED EQUIPMENT

The customer shall be responsible for providing all NFPA required miscellaneous equipment that is not contained within these specifications. All required equipment must be properly installed on the apparatus and in working condition prior to the apparatus being placed into service.

FAMILIARIZATION AND DEMONSTRATION

Toyne Inc.

Upon completion of the new apparatus, an authorized properly trained representative of the manufacturer shall perform a "Familiarization and Demonstration" overview of the apparatus and related components.

The Department shall provide the representative with a written list, by full proper names, of the individual(s) that are to receive the overview. Upon completion of the overview, each person in attendance will be required to acknowledge, by signature, that they understand the operation of the apparatus and all related components.

CHASSIS FAMILIARIZATION

Familiarization of the apparatus shall include the following:

- How to locate gauges or indicators and check all fluid levels and operational use of the apparatus.
- How to tilt the chassis cab or hood assembly for access to the engine, fire pump (if applicable), or aerial control (if applicable), or any other device to allow access to fluids or for required maintenance.
- Interior cab controls, instruments, mirrors, safety devices or alarms, brake operations, transmission control, pump controls (if applicable) exhaust regeneration (if applicable), seat adjustments, warning light engagement and other operational equipment.

POST ACCEPTANCE TRAINING REQUIREMENTS

After apparatus acceptance, the Department shall be responsible for ongoing training of personnel. The Department shall not allow untrained or undertrained personnel to operate the apparatus or any included feature of the apparatus.